

COMMERCIAL CONDENSING UNITS TECHNICAL MANUAL

V3

V3 INVERTER SINGLE SCROLL Commercial Condensing Units Variable Capacity

Medium Temperature Applications

ISSUE: 01.06.2023



UK
CA CE

J&E Hall
International

IMPORTANT!

READ BEFORE PROCEEDING!

GENERAL SAFETY GUIDELINES



This guideline is intended for users to ensure safe installation, operation, and maintenance of J & E Hall INVERTER condensing units. This guideline is not intended to replace the system expertise available from the system manufacturers.

This equipment is a relatively complicated apparatus. During installation, operation, maintenance or service, individuals may be exposed to certain components or conditions including, but not limited to: refrigerants, materials under pressure, rotating components, and both high and low voltage. Each of these items has the potential, if misused or handled improperly, to cause bodily injury or death. It is the obligation and responsibility of operating/service personnel to identify and recognize these inherent hazards, protect themselves, and proceed safely in completing their tasks. Failure to comply with any of these requirements could result in serious damage to the equipment and the property in which it is situated, as well as severe personal injury or death to themselves and people at the site.

This document is intended for use by owner-authorized operating/service personnel. It is expected that these individuals possess independent training that will enable them to perform their assigned tasks properly and safely. It is essential that, prior to performing any task on this equipment, this individual shall have read and understood this document and any referenced materials. This individual shall also be familiar with and comply with all applicable governmental standards and regulations pertaining to the task in question.

SAFETY SYMBOLS

The following symbols are used in this document to alert the reader to specific situations:

 WARNING	Warning! Risk of serious injury or death to person!
 CAUTION	Caution! Danger which can lead to serious damages!
 NOTICE	Notice! Risk of damage to equipment!

NOTICE



Disposal requirement:

Your refrigeration product is marked with this symbol. This means that electrical and electronic products shall not be mixed with unsorted household waste. Do not try to dismantle the system yourself: the dismantling of the refrigeration system, treatment of the refrigerant, of oil and of other parts must be done by a qualified installer in accordance with relevant local and national legislation. Refrigeration equipment must be treated at a specialized treatment facility for re-use, recycling, and recovery.

By ensuring this product is disposed of correctly, you will help to prevent potential negative consequences for the environment and human health. Please contact J & E Hall for more information.

Batteries must be removed from the controller and disposed of separately in accordance with relevant local and national legislation.

Contents

PRODUCT FEATURES	1	SWITCH UNIT ON/OFF (BY CONTROLLER)	14
NOMENCLATURE	1	COMPRESSOR MODEL SELECTION	14
<i>Figure 1: Product Nomenclature</i>	1	<i>Table 13: List of Compressor in Controller</i>	14
SPECIFICATIONS	1	COMPRESSOR OPERATION	14
<i>Table 1: Exploded View Indicator</i>	1	<i>Figure 11: Compressor Operating Zone</i>	15
<i>Figure 2: Exploded View of JEHSI-033-B3-M-3; JEHSI-066-B3-M-3</i>	2	INVERTER COMPRESSOR START-UP:	15
<i>Figure 3: Exploded View of JEHSI-087-B4-M-3</i>	2	<i>Figure 12: Compressor Startup Curve</i>	15
<i>Table 2: Unit Data</i>	3	PRESSURE DIFFERENTIAL DURING START-UP	15
<i>Table 3: Unit SEPR, Sound Data, Dimension and Weight</i>	3	TIMES	15
<i>Table 4: Performance Data of JEHSI-033-B3-M-3 (R448A/ R449A)</i>	4	<i>Figure 13: Times Control for Compressor Startup</i> ...	15
<i>Table 5: Performance Data of JEHSI-066-B3-M-3 (R448A/ R449A)</i>	5	COMPRESSOR CONTROL	16
<i>Table 6: Performance Data of JEHSI-087-B4-M-3 (R448A/ R449A)</i>	6	<i>Figure 14: Proportional Control</i>	16
APPLICATION GUIDELINES	7	<i>Figure 15: Proportional + Integral Control</i>	16
CONDENSING UNIT SELECTION	7	AC FAN SPEED MODULATION	16
<i>Table 7: Compressor Speed Range</i>	7	<i>Figure 16: Fan Control Curve</i>	16
<i>Table 8: Operating Limit</i>	7	<i>Table 14: Fan Settings for Ecodesign Data</i>	16
COMPRESSOR	7	MECHANICAL SAFETY PRESSURE SWITCH	16
HEALTH AND SAFETY	7	HIGH DISCHARGE TEMPERATURE MANAGEMENT	17
GENERAL INFORMATION	7	<i>Figure 17: Discharge Temperature Management</i> ...	17
INSTALLATION	8	SYSTEM CHARGE	17
UNIT LOCATION	8	PIPE SIZE SELECTION	18
<i>Figure 4: Positioning of Condensing Unit</i>	8	<i>Figure 18: Suction Pipe Layout for 1 outdoor to 2 indoors</i>	18
<i>Figure 5: Air Circulation for Condenser</i>	8	<i>Table 15: Suction Pipe Size Selection</i>	18
INSTALLATION CLEARANCES	8	CONTROLLER SETTINGS	19
<i>Figure 6: Installation Clearance</i>	8	<i>Table 16: Controller Default Settings</i>	19
FIELD PIPING	9	ALARM SETTINGS	21
<i>Figure 7: Piping layout for outdoor above indoor</i>	9	<i>Table 17: List of Alarm Code</i>	21
<i>Figure 8: Piping layout for outdoor below indoor</i>	9	<i>Table 18: LCD Display - Alarm Status</i>	21
PRESSURE TESTING	10	<i>Table 19: Details Error Code from Activation of ALW25</i>	22
<i>Table 9: Test Pressure</i>	10	SERVICE AND MAINTENANCE	23
EVACUATION AND CHARGING	10	<i>Table 20: Tightening Torque</i>	23
ELECTRICAL	10	F-GAS REQUIREMENT	24
<i>Table 10: Recommended wiring sizes</i>	10	<i>Table 21: Leak Inspection Frequency</i>	24
PHASE SEQUENCE FOR CORRECT COMPRESSION	11	BACNET AND MODBUS PROTOCOL	24
WARNING WHEN TOUCHING UNIT WHEN OFF	11	<i>Figure 19: Location of Serial Port on Controller</i>	24
EARTH LEAKAGE CURRENT	11	SOFTWARE UPDATE	24
COMMISSIONING	11	<i>Figure 20: pCO Smart Key</i>	24
<i>Figure 9: Access Point</i>	11	APPENDIX	25
ACCESS TO CONTROLLER AND LCD DISPLAY	11	<i>Figure 21: Outline Drawing JEHSI-033-B3-M-3, JEHSI-066-B3-M-3</i>	25
<i>Table 11: Factory Default Setting</i>	12	<i>Figure 22: Outline Drawing JEHSI-087-B4-M-3</i>	25
USER TERMINAL INTERFACE – LCD DISPLAY	12	<i>Figure 23: Wiring Diagram JEHSI-033-B3-M-3</i>	26
<i>Figure 10: LCD Display</i>	12	<i>Figure 24: Wiring Diagram JEHSI-066-B3-M-3</i>	27
<i>Table 12: LCD Display Button Functions</i>	12	<i>Figure 25: Wiring Diagram JEHSI-087-B4-M-3</i>	28
CONTROLLER HOME SCREEN	13	<i>Figure 26: Declaration of Conformity</i>	29
PASSWORD FOR ACCESSIBILITY LEVEL	13	<i>Figure 27: Declaration of Incorporation</i>	30
CHANGING SET POINT	13	<i>Figure 28: EU Declaration of Conformity</i>	31
REFRIGERANT SELECTION	13	<i>Figure 29: EU Declaration of Incorporation</i>	32

Product Features

J & E Hall INVERTER condensing unit adopt stepless inverter scroll technology with energy efficiency 20-30% higher in a flexible plug and play package, for medium temperature refrigeration application.

Standard features for all medium temperature model:

- SCI hermetic high pressure dome BLDC scroll compressor and crankcase heater
- Compressor Drive (with EMI filter) integrates protection functions: short circuit, overcurrent, ground fault, over voltage and under voltage, over temperature.
- Advanced programmable controller integrates the function of oil speed boost for oil return to compressor, discharge superheat control, ample configuration of alarms.
- Capacity modulation based on fixed pressure set point (floating suction setpoint is available when exploiting serial communication with evaporators)
- Vertical liquid receiver with stop valve and 3/8" NPT plug
- Fitted with brazed type liquid line drier and sight glass
- Oil separator and discharge line non returned valve
- External service valves
- Suction and discharge pressure transducers
- Suction, discharge, and ambient temperature sensors
- Low pressure switch (adjustable) – default: auto reset
- High pressure safety switch (manual reset cartridge type)
- Mains switch for isolation of incoming power supply
- Manual motor starter for isolation and protection on 3phase AC Drive
- Fuse protection for 1phase controller and fan motor
- LCD display
- Flexible pressure hoses
- IP rated enclosure
- Fan speed controller
- Acoustic insulation on compressor compartment
- Robust weatherproof housing
- BACnet and Modbus Protocol feature
- Approved refrigerants: R448A and R449A

Nomenclature

Figure 1: Product Nomenclature

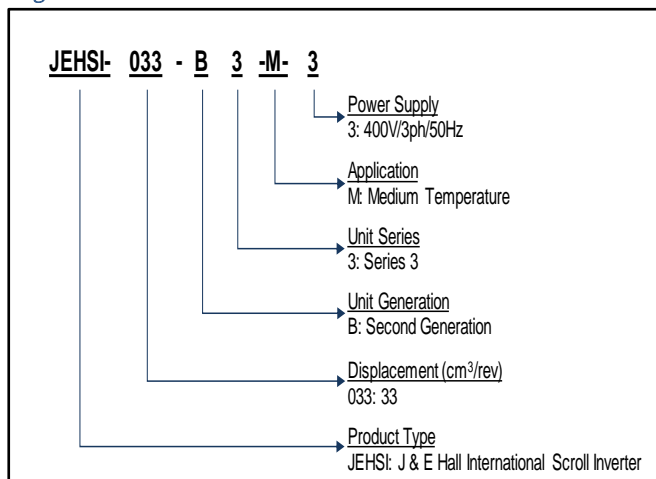

Specifications

Table 1: Exploded View Indicator

Item	Description
1	COMPRESSOR
2	DRIVE
3	HEATER
4	LIQ. RECEIVER
5	OIL SEPARATOR
6	FAN PROPELLER
7	FAN MOTOR
8	FAN
9	FAN CAPACITOR
10	FAN GUARD
11	COMPRESSOR OIL
12	CONDENSER
13	ISOLATOR
14	ISOLATOR-N
15	ISOLATOR HANDLE
16	MCB
17	CONTROLLER
18	FAN SPEED CONTROLLER
19	DC CHOKE
20	CONTROL RELAY
21	CONTROL RELAY
22	CONTROL RELAY
23	REMOTE DISPLAY
24	CABLE REMOTE DISPLAY
25	PRESSURE SWITCH LOW
26	PRESSURE SWITCH HIGH
27	SENSOR PRESSURE SUCTION
28	SENSOR PRESSURE DISCHARGE/ VI
29	CABLE PRESSURE TRANSDUCER
30	SENSOR TEMPERATURE SUCTION/ VI
31	SENSOR TEMPERATURE DISCHARGE T
32	SENSOR TEMPERATURE AMBIENT
33	FUSE
34	VALVE SERVICE
35	VALVE DISCHARGE LINE
36	VALVE NON - RETURN
37	FILTER DRIER
38	SIGHT GLASS
39	GOMEX LOW PRESSURE
40	GOMEX OIL RETURN
41	BRACKET SERVICE VALVE
42	PANEL BASE
43	PANEL FAN
44	PANEL FAN TOP
45	PANEL LEFT
46	PILLAR LEFT-REAR
47	PANEL REAR
48	PILLAR FRONT RIGHT
49	PILLAR FRONT LEFT
50	PANEL RIGHT
51	PANEL FRONT
52	PANEL FRONT TOP
53	PANEL TOP
54	BRACKET FAN MOTOR
55	BRACKET ADAPTOR FAN MOTOR
56	BRACKET OIL SEP.
57	PARTITION FAN
58	BRACKET DRIVE
59	CONTROL BOX COVER DISPLAY
60	CONTROL BOX COVER
61	PANEL MIDDLE
62	BRACKET LIQUID PIPE

Figure 2: Exploded View of JEHSI-033-B3-M-3; JEHSI-066-B3-M-3

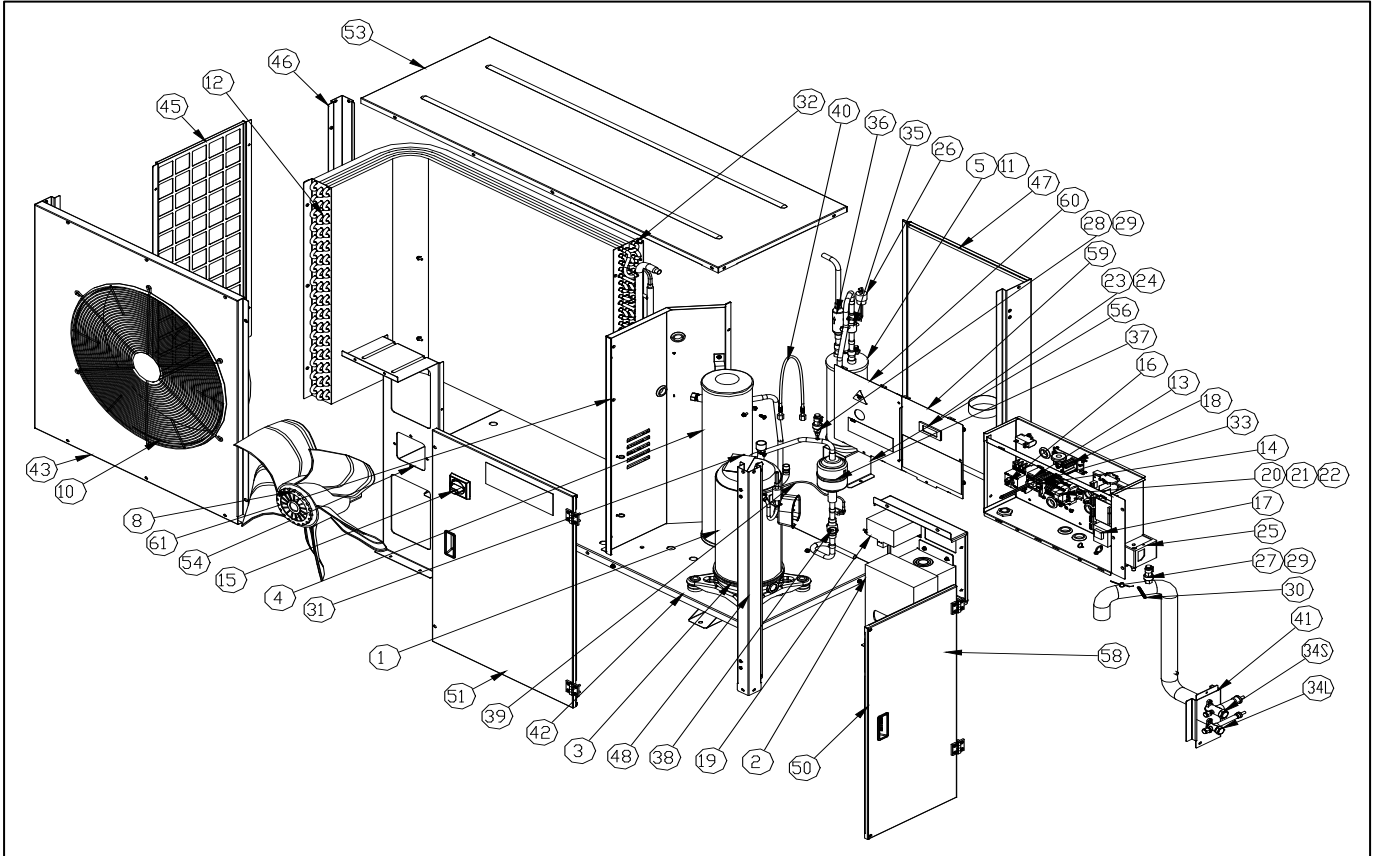

Figure 3: Exploded View of JEHSI-087-B4-M-3

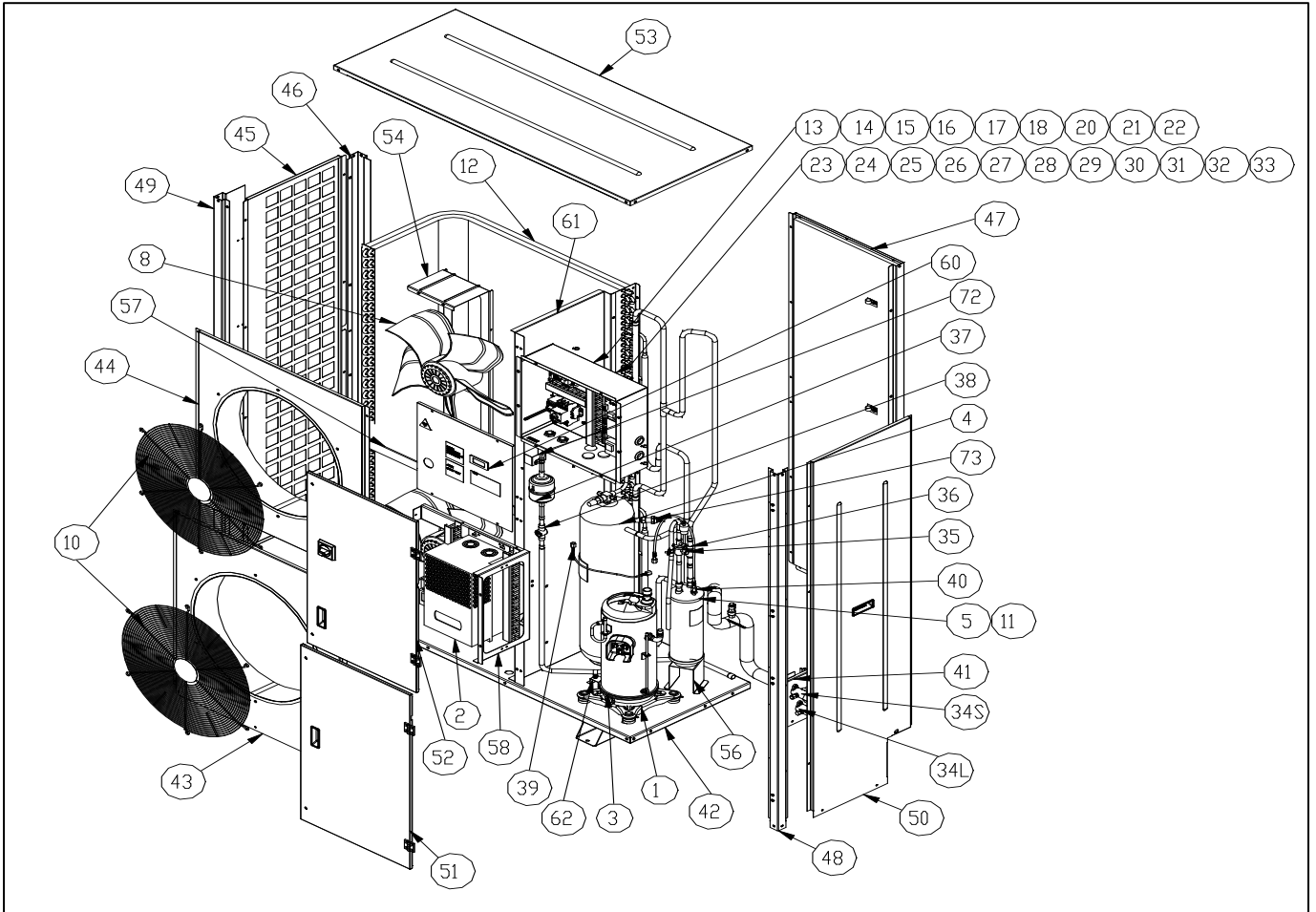

Table 2: Unit Data

Casing	Model	Appl.	Compressor			Oil Separator	Electrical Data				Unit Connections		Coil Volume (L)	Air flow (m ³ /h)	Liquid Receiver (L)
			Model	Displacement (cm ³ /rev)	Oil Charge (L)		Compressor		Fan Motors		Liquid (inch)	Suction (inch)			
					(L)	(L)	NC	MCC	No.	FLC (A)	(inch)	(inch)			
3	JEHSI-033-B3-M-3	MT	AGK33FDAMTS	33.2	1.9	0.6	3.9	10.8	1	0.5	1/2"	5/8"	4.42	3350	6.2
	JEHSI-066-B3-M-3		AGK66FDBMTS	66.0	2.3	0.6	7.0	17.5	1	0.9	1/2"	3/4"	6.89	4100	6.2
4	JEHSI-087-B4-M-3		AGK87FDCMTS	87.1	2.3	0.6	8.8	24.0	2	1.8	3/4"	7/8"	8.73	8500	13.6

- Compressor Lubricant: K) Hermetic Oil FVC56EA
- NC: Nominal Current @ condition -10°C Te/ +32°C Ta
- MCC: Maximum Continuous Current
- FLC: Full Load Current

Table 3: Unit SEPR, Sound Data, Dimension and Weight

Model	SEPR (10K SH)		SPL @ 10m dB(A)	Overall Dimensions (mm)			Mounting Dimensions (mm)		Dry Weight (kgs)	Gross Weight (kgs)
	R448A	R449A		Width	Depth	Height	Width	Depth		
JEHSI-033-B3-M-3	3.03	3.03	31.3	1334	546	872	945	500	116	154
JEHSI-066-B3-M-3	3.39	3.39	39.8	1334	546	872	945	500	134	172
JEHSI-087-B4-M-3	3.60	3.60	44.1	1348	600	1727	940	560	212	271

- Seasonal Energy Performance Ratio (SEPR) rating condition @ condition -10°C Te, suction superheat (SH) 10K.
- Sound Pressure Level (SPL) measured in an anechoic room at -10°C Te/+32°C Ta MT conditions at 60rps. Alternative conditions may produce different results.

The performance data shown in the **Table 4 to 6** has the following criteria:

- Te: Evaporating Temperature
- Ta: Ambient Temperature
- CC: Cooling Capacity (Watts)
- PC: Power Consumed (Watts)
- Data presented in accordance with BS EN13215:2016
- SH: Suction Superheat 10K
- SC: Subcooling 0K
- COP: Coefficient of Performance

Table 4: Performance Data of JEHSI-033-B3-M-3 (R448A/ R449A)

MODEL	SPEED, rps	Te		-20	-15	-10	-5	0	5
		Ta							
JEHSI-033-B3-M-3	30	27	CC	1567	1881	2246	2667	3149	3695
	30	27	PC	884	930	975	1020	1066	1111
	30	27	COP	1.77	2.02	2.30	2.61	2.95	3.33
	30	32	CC	1497	1795	2142	2542	2999	3517
	30	32	PC	905	978	1050	1123	1195	1268
	30	32	COP	1.65	1.84	2.04	2.26	2.51	2.77
	30	35	CC	1453	1742	2077	2463	2905	3406
	30	35	PC	918	1006	1095	1184	1272	1361
	30	35	COP	1.58	1.73	1.90	2.08	2.28	2.50
	30	38	CC	1408	1687	2011	2383	2809	3293
	30	38	PC	930	1035	1140	1245	1350	1455
	30	38	COP	1.51	1.63	1.76	1.91	2.08	2.26
	60	27	CC	3239	3873	4582	5368	6231	7173
	60	27	PC	1733	1757	1780	1803	1827	1850
	60	27	COP	1.87	2.20	2.57	2.98	3.41	3.88
	60	32	CC	3058	3665	4348	5110	5951	6875
	60	32	PC	1750	1840	1930	2020	2110	2200
	60	32	COP	1.75	1.99	2.25	2.53	2.82	3.13
	60	35	CC	2943	3535	4203	4949	5778	6693
	60	35	PC	1760	1890	2020	2150	2280	2410
	60	35	COP	1.67	1.87	2.08	2.30	2.53	2.78
	60	38	CC	2825	3401	4053	4785	5602	6507
	60	38	PC	1770	1940	2110	2280	2450	2620
	60	38	COP	1.60	1.75	1.92	2.10	2.29	2.48
	80	27	CC	4116	4906	5795	6788	7891	9110
	80	27	PC	2587	2661	2735	2809	2883	2957
	80	27	COP	1.59	1.84	2.12	2.42	2.74	3.08
	80	32	CC	3908	4659	5503	6446	7496	8657
	80	32	PC	2470	2640	2810	2980	3150	3320
	80	32	COP	1.58	1.76	1.96	2.16	2.38	2.61
	80	35	CC	3780	4506	5322	6235	7252	8379
	80	35	PC	2400	2628	2855	3082	3310	3537
	80	35	COP	1.57	1.71	1.86	2.02	2.19	2.37
	80	38	CC	3649	4349	5137	6020	7003	8096
	80	38	PC	2330	2615	2900	3185	3470	3755
	80	38	COP	1.57	1.66	1.77	1.89	2.02	2.16
	100	27	CC	5068	6004	7051	8217	9511	10938
	100	27	PC	3008	3182	3355	3528	3702	3875
	100	27	COP	1.68	1.89	2.10	2.33	2.57	2.82
	100	32	CC	4826	5713	6704	7807	9030	10380
100	32	PC	3160	3385	3610	3835	4060	4285	
100	32	COP	1.53	1.69	1.86	2.04	2.22	2.42	
100	35	CC	4678	5535	6491	7554	8734	10037	
100	35	PC	3125	3412	3700	3988	4275	4563	
100	35	COP	1.50	1.62	1.75	1.89	2.04	2.20	
100	38	CC	4527	5353	6274	7297	8433	9760	
100	38	PC	3090	3440	3790	4140	4490	4840	
100	38	COP	1.47	1.56	1.66	1.76	1.88	2.02	

Table 5: Performance Data of JEHSI-066-B3-M-3 (R448A/ R449A)

MODEL	SPEED, rps	Te Ta		-20	-15	-10	-5	0	5
JEHSI-066-B3-M-3	30	27	CC	2937	4130	5324	6517	7710	8903
	30	27	PC	1706	1749	1793	1836	1880	1924
	30	27	COP	1.72	2.36	2.97	3.55	4.10	4.63
	30	32	CC	2827	3897	4966	6036	7105	8175
	30	32	PC	1770	1860	1950	2040	2130	2220
	30	32	COP	1.60	2.09	2.55	2.96	3.34	3.68
	30	35	CC	2761	3756	4752	5747	6742	7737
	30	35	PC	1810	1928	2045	2163	2280	2397
	30	35	COP	1.53	1.95	2.32	2.66	2.96	3.23
	30	38	CC	2695	3616	4537	5458	6379	7300
	30	38	PC	1850	1995	2140	2285	2430	2575
	30	38	COP	1.46	1.81	2.12	2.39	2.63	2.83
	60	27	CC	5004	7134	9263	11393	13523	15653
	60	27	PC	3103	3347	3592	3836	4080	4324
	60	27	COP	1.61	2.13	2.58	2.97	3.31	3.62
	60	32	CC	4787	6694	8600	10507	12413	14320
	60	32	PC	3270	3560	3850	4140	4430	4720
	60	32	COP	1.46	1.88	2.23	2.54	2.80	3.03
	60	35	CC	4805	6540	8276	10011	11747	13483
	60	35	PC	3463	3758	4052	4346	4640	4934
	60	35	COP	1.39	1.74	2.04	2.30	2.53	2.73
	60	38	CC	4781	6356	7931	9506	11081	12679
	60	38	PC	3630	3935	4240	4545	4850	5155
	60	38	COP	1.32	1.62	1.87	2.09	2.28	2.46
	80	27	CC	8479	10114	11749	13383	15018	16653
	80	27	PC	4402	4779	5156	5533	5910	6287
	80	27	COP	1.93	2.12	2.28	2.42	2.54	2.65
	80	32	CC	7723	9386	11049	12712	14375	16038
	80	32	PC	4540	4995	5450	5905	6360	6815
	80	32	COP	1.70	1.88	2.03	2.15	2.26	2.35
	80	35	CC	7153	8862	10571	12280	13989	15698
	80	35	PC	4690	5175	5660	6145	6630	7115
	80	35	COP	1.53	1.71	1.87	2.00	2.11	2.21
	80	38	CC	6615	8362	10109	11856	13603	
	80	38	PC	4820	5340	5860	6380	6900	
	80	38	COP	1.37	1.57	1.73	1.86	1.97	
	100	27	CC	9980	11765	13549	15334		
	100	27	PC	5932	6342	6753	7164		
	100	27	COP	1.68	1.85	2.01	2.14		
	100	32	CC	9037	11117	13196	15276		
100	32	PC	6190	6710	7230	7750			
100	32	COP	1.46	1.66	1.83	1.97			
100	35	CC	8471	10728	12984	15241			
100	35	PC	6345	6904	7462	8021			
100	35	COP	1.33	1.55	1.74	1.90			
100	38	CC	7905	10339	12773	15207			
100	38	PC	6500	7105	7710	8315			
100	38	COP	1.22	1.46	1.66	1.83			

Table 6: Performance Data of JEHSI-087-B4-M-3 (R448A/ R449A)

MODEL	SPEED, rps	Te Ta		-20	-15	-10	-5	0	5
JEHSI-087-B4-M-3	30	27	CC	3401	4600	5799	7269	8740	10211
	30	27	PC	2465	2469	2473	2478	2482	2486
	30	27	COP	1.38	1.86	2.34	2.93	3.52	4.11
	30	32	CC	3328	4220	5112	6310	7508	8706
	30	32	PC	2740	2740	2740	2740	2740	2740
	30	32	COP	1.21	1.54	1.87	2.30	2.74	3.18
	30	35	CC	3282	3991	4700	5735	6769	7804
	30	35	PC	2905	2902	2900	2898	2895	2893
	30	35	COP	1.13	1.38	1.62	1.98	2.34	2.70
	30	38	CC	3235	3762	4288	5159	6030	6901
	30	38	PC	3070	3065	3060	3055	3050	3045
	30	38	COP	1.05	1.23	1.40	1.69	1.98	2.27
	60	27	CC	6915	9483	12050	15050	18050	21049
	60	27	PC	4460	4648	4835	5023	5210	5398
	60	27	COP	1.55	2.04	2.49	3.00	3.46	3.90
	60	32	CC	6609	8644	10680	13449	16217	18986
	60	32	PC	5160	5285	5410	5535	5660	5785
	60	32	COP	1.28	1.64	1.97	2.43	2.87	3.28
	60	35	CC	6410	8134	9857	12487	15118	17748
	60	35	PC	5580	5668	5755	5843	5930	6018
	60	35	COP	1.15	1.44	1.71	2.14	2.55	2.95
	60	38	CC	6199	7617	9035	11527	14018	16510
	60	38	PC	6000	6050	6100	6150	6200	6250
	60	38	COP	1.03	1.26	1.48	1.87	2.26	2.64
	80	27	CC	9718	12601	15485	18266	21048	23830
	80	27	PC	6486	6647	6808	6969	7130	7291
	80	27	COP	1.50	1.90	2.27	2.62	2.95	3.27
	80	32	CC	9416	11589	13762	16480	19198	21916
	80	32	PC	6920	7210	7500	7790	8080	8370
	80	32	COP	1.36	1.61	1.83	2.12	2.38	2.62
	80	35	CC	9225	10977	12729	15408	18088	20768
	80	35	PC	7180	7547	7915	8282	8650	9018
	80	35	COP	1.28	1.45	1.61	1.86	2.09	2.30
	80	38	CC	9028	10361	11695	14337	16978	
	80	38	PC	7440	7885	8330	8775	9220	
	80	38	COP	1.21	1.31	1.40	1.63	1.84	
	100	27	CC	12134	14791	17449	20098	22748	25397
	100	27	PC	9795	9839	9883	9928	9972	10016
	100	27	COP	1.24	1.50	1.77	2.02	2.28	2.54
	100	32	CC	11703	13906	16109	19296	22483	25670
100	32	PC	10120	10235	10350	10465	10580	10695	
100	32	COP	1.16	1.36	1.56	1.84	2.13	2.40	
100	35	CC	11431	13368	15306	18815	22325	25834	
100	35	PC	10315	10472	10630	10788	10945	11103	
100	35	COP	1.11	1.28	1.44	1.74	2.04	2.33	
100	38	CC	11150	12826	14502	18334	22166		
100	38	PC	10510	10710	10910	11110	11310		
100	38	COP	1.06	1.20	1.33	1.65	1.96		

Application Guidelines

Condensing Unit Selection

Selection of the correct size of inverter condensing unit as method below:

Select a condensing unit size which achieves the peak load system cooling capacity demand at its maximum speed.



NOTICE

It should ensure that the condensing unit capacity at minimum speed (30rps) is not higher than the necessary cooling capacity for the smallest evaporator in the system. Failure to meet this criterion will cause condensing

unit work outside its application envelope and as consequence reduce lifetime.

Example (R448A, Evaporating temperature: -10°C , Ambient temperature 32°C):

Evaporator 1: 5kW

Evaporator 2: 3kW

Evaporator 3: 2.6kW

Evaporator 4: 2.5kW

Total maximum cooling capacity = 13.1kW

Minimum cooling capacity = minimum evaporator capacity = 2.5kW

According to the capacities R448A at $T_e = -10^{\circ}\text{C}$, $T_a = 32^{\circ}\text{C}$, condensing unit JEHSL-066-B4-M-3 (maximum capacity 13.2kW and minimum capacity 5.0kW)

Condensing unit maximum capacity 13.2kW achieves the peak load system cooling capacity 13.1kW but minimum speed 30rps which deliver minimum capacity exceed the necessary cooling capacity for the smallest evaporator (2.5kW).

In above case, it is recommended to connect few evaporators together (regulated by one thermostat) to achieve smallest required capacity higher than the minimum capacity of the condensing unit: by connecting Evaporator 3 and Evaporator 4 via one common thermostat (2.6kW + 2.5kW = 5.1kW), which is higher than the minimum capacity of the condensing unit (5.0kW)

Table 7: Compressor Speed Range

Compressor speed	Minimum	Maximum
rps	30	100
rpm	1800	6000

Indicator:

rps: revolution per second of motor shaft (rotor)

rpm: revolution per minute of motor shaft (rotor)

$rps = rpm / 60$

Suction line shall be insulated to avoid:

- High superheat during high ambient condition can create high discharge temperature.
- Too low superheat during low ambient condition that can condense refrigerant inside suction line.

Table 8: Operating Limit

Operating Limits	Recommendation
Discharge gas temperature	110°C maximum
Evaporator outlet superheat	Above 6K (to avoid liquid flood back)
Suction gas superheat at compressor inlet	Not more than 20K
Voltage supply	Min: 360V, Max: 440V
Phase asymmetry	+/- 3%
Frequency	50Hz +/- 1%
Outdoor ambient	Min: -15°C , Max: 43°C (contact J&E Hall Limited if high ambient data is required)

Compressor



CAUTION

The scroll compressor inside J&E Hall INVERTER condensing unit is a high-pressure dome compressor, with 6 poles brushless DC motor (BLDCM). The compressor cannot operate without the frequency converter. It will be destroyed immediately if connected directly to the public network.

The pressure inside the shell of compressor is a high (discharge) pressure and have high temperature. Care must be taken when orientating the power supply cables to the main isolator. Never touch the power supply cable to the body of compressor, unless heat resistant cables are used.

Health and Safety



CAUTION

J & E Hall Inverter Condensing Unit must be installed and commissioned by competent personnel, who are familiar with refrigeration systems and components including all controls. To avoid potential injury, use care when working around coil surfaces or sharp edges of metal cabinets. All piping and electrical wiring should be installed in accordance with all applicable standards and local laws.

General Information

Before Installation

- Ensure the units received are the correct models for the intended application.
- Ensure the refrigerant, electrical supply and maximum working pressure are all suitable for the proposed application.
- Check there is no damage to the units. Any damage should be reported to the supplier immediately.
- Check that the proposed equipment locations are suitable and provide adequate support for the weight of the units.

Offloading and Lifting

- Whenever a condensing unit is lifted, it should be from the base and, where possible, all packing and protection is kept in position.

- If lifting equipment is required, ensure that it is suitable, certificated, and that the operators are qualified to use it.
- When using a fork-lift or pallet truck to lift the unit, the two support points should be sufficiently apart to give stability when lifting and suitably placed to distribute the load on the forks.
- If slings are used, care should be taken to ensure that the slings do not crush the casework or coil.
- When lifting by crane, use spreader bars to prevent compressing the top of the equipment.
- Do not drop the unit. Should this inadvertently happen, it should be immediately unpacked and inspected for damage.
- Use the appropriate spreader bars/lifting sling with the holes and lugs provided.

During Installation and subsequent maintenance

- Installation and maintenance are to be performed only by qualified personnel who are familiar with local codes and regulations and experienced with this type of equipment.
- Safe working methods are identified, and operatives have suitable Personal Protective Equipment (PPE).
- Ensure the working area has adequate ventilation during brazing procedures.
- The units contain moving machinery and electrical power hazards, which may cause severe injury or death. Disconnect and shut off power and wait until all LEDs on frequency converter goes off before installation or service of the equipment.
- Refrigerant release into the atmosphere is illegal. Proper evacuation, recovery, handling, and leak testing procedures must be observed all the time.
- Units must be earthed.
- No maintenance work should be attempted prior to disconnecting the electrical supply.
- The electrical covers and fan guards must remain always fitted.
- Use of the units outside of the design conditions and the application for which the units were intended may be unsafe and be detrimental to the units, regardless of short term or long-term operation.
- The units are not designed to withstand loads or stress from other equipment or personnel. Such extraneous loads or stress may cause failure/leak/injury.
- The installer must fix the unit securely on installation using the M8 bolt holes in the unit feet to prevent instability from accidental contact or from exposure to the elements (e.g., wind).
- The units are not designed to operate with any restrictions such as heavy snowfall around them. Additional measures (such as shielding of the units) shall be implemented as required.

Installation

Unit location

- To achieve maximum cooling capacity, the installation location for the condensing unit should be carefully selected.
- Install the condensing unit in such a way so that hot air ejected by the condensing unit cannot be drawn in

again (short circuit of hot discharge air). Allow sufficient space for maintenance around the unit.

Figure 4: Positioning of Condensing Unit

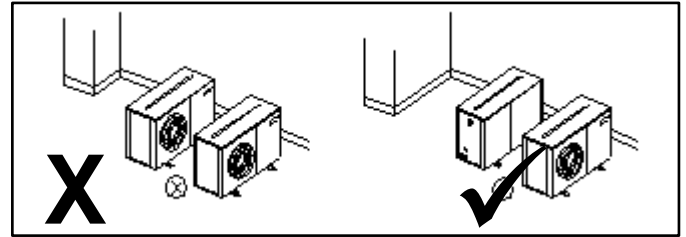

- Ensure that there is no obstruction to air flow into or out of the unit. Remove obstacles which block air intake or discharge.

Figure 5: Air Circulation for Condenser

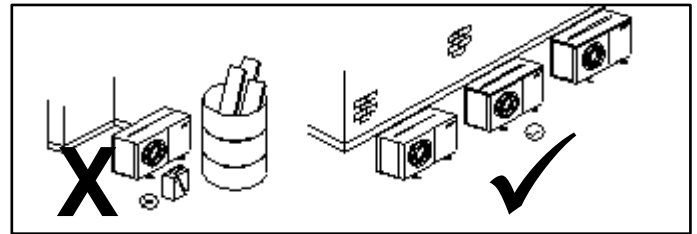

- The location must be well ventilated, so the unit can draw in and distribute plenty of air thus lowering the condensing temperature.
- Air leaving the condenser should avoid facing prevailing wind, which impedes air flow and thus causing high condensing temperature.
- To optimize the unit running conditions, the condenser coil must be cleaned at regular intervals.
- The unit must be level in all directions.
- It is recommended to install the unit on rubber grommet or vibration dampers.
- Models JEHSI-033 and JEHSI-066 are suitable for both ground and wall mounting on brackets, but JEHSI-087 is only suitable for ground mounting.



NOTICE

Special attention should be given if unit installed near to the sea as this can reduce unit lifespan due to corrosion of metal parts.

Installation Clearances

The installation location should allow sufficient space for air flow and maintenance around the unit.

Figure 6: Installation Clearance

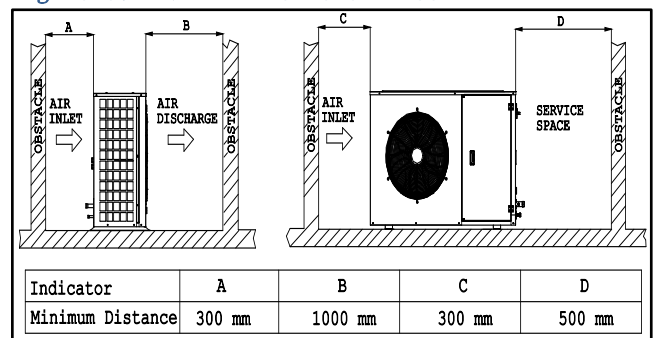

Field Piping



NOTICE

Pipe sizing should only be determined by qualified personnel. Correct line sizing will minimize the pressure drop and maintain sufficient gas velocity for proper oil return.

All applicable standards must be observed in the installation of refrigerant piping.

To ensure satisfactory operation and performance, the following points should be noted:

- Pipework routes must be as simple and as short as possible.
- Avoid low points on pipework where oil can accumulate.
- Suction gas velocity must be sufficient to ensure good oil return.
- Use only clean, dehydrated refrigeration grade copper tube with long radius bends.
- Avoid flare type connections and take great care when brazing. Use brazing filler alloys containing phosphorus such as BCuP-7 without flux for joining copper tubes.
- Dissimilar metals such as copper and brass shall be joined using an appropriate flux with high silver content filler material such as BA9-34. Apply flux sparingly to the clean tube only and in a manner to avoid leaving any excess inside of completed joints.
- Run braze without over filling to ensure there is no leakage into the tube.
- To prevent oxidation, blow oxygen free nitrogen through pipework when brazing.
- Install insulation on all suction lines and on all pipes penetrating walls or passing through hot areas.
- Adequately support all pipework at a maximum of 2m intervals.
- Where the condensing unit is situated below the indoor unit (coldroom evaporator / display case), the height difference between the two units should be no more than 6 meters.
- In vertical pipework, the use of U-trap and double suction risers is often required. These suction risers must always be fitted with a U-trap at the bottom and a P-trap at the top and never be higher than 4m unless a second U-trap system is fitted.
- Additional oil may be required if piping length exceeds 20m or multiple oil traps are fitted. Check the oil level closely during commissioning and add oil as necessary. Add oil in small amounts. Do not overfill the compressor!
- Suction pipework should slope gently back towards the unit to assist oil return to the compressor. A fall of approximately 2cm per meter of pipework is acceptable.
- Liquid lines should be sized to ensure a full supply of liquid refrigerant to the expansion device. Careful attention should be paid to sizing of liquid lines on large risers (maximum rise 6m).
- In some circumstances, a suction accumulator (not supplied) may be required. It offers protection against refrigerant flood back during operation and against off-cycle migration by adding internal free volume to the low side of the system.
- Tests must be conducted to ensure the amount of off-cycle migration to the compressor does not exceed the compressor's charge limit of 6kgs.
- All evaporators must have their own thermostat/liquid line solenoid valve.

- The maximum recommended pipe length is 25m from the closest indoors.
- It is recommended to install Pressure Relief Valve on the liquid receiver if there is a risk of fire incidence. Increasing temperature will lead to pressure increase in receiver.
- No valves and detachable joints shall be in areas accessible to the public except when they comply with EN 16084.
- Field piping for outdoor unit located below indoor unit: Inverted P-trap is necessary (**Figure 8**). To prevent refrigerant from draining into the compressor during off-cycle.



NOTICE

One of the main factors affecting equipment reliability and compressor service life is refrigeration circuit contamination.

During installation, circuit contamination can be caused by:

- Brazing & Welding Oxides
- Filings & Particles from de-burring pipework
- Brazing Flux
- Moisture & Air

Figure 7: Piping layout for outdoor above indoor

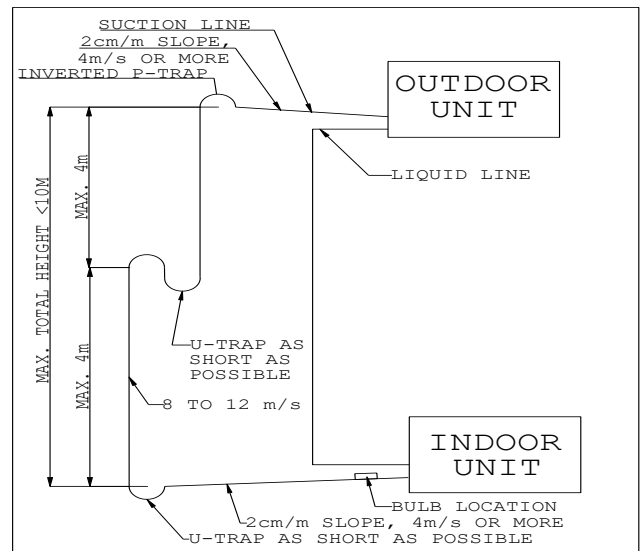
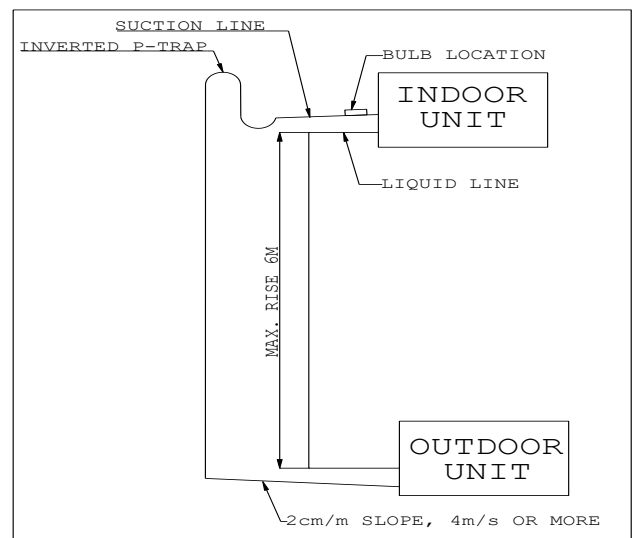

Figure 8: Piping layout for outdoor below indoor



Pressure Testing

- The condensing units are pressure tested in the factory prior to dispatch. All units come with a holding charge of oxygen free nitrogen. Remove the holding charge and indication tag prior to pipework installation using the service valve or regulator with pressure gauges and hoses.
- Once the pipework installation is complete, it should be pressure tested prior to evacuation to test for leaks.
- A pressure leak test should be carried out using oxygen free nitrogen (OFN). NEVER USE OXYGEN FOR PRESSURE TESTING SYSTEMS. A calibrated nitrogen pressure regulator must always be used. Before starting any pressure testing, ensure the area surrounding the system is safe, inform relevant personnel and fit warning signs indicating high pressure testing. Also, use correct Personal Protection Equipment (PPE) as required.
- Always pressurize the system slowly, preferably in stages up to the maximum required pressure. Maximum test pressures applicable to the unit are as follows:

Table 9: Test Pressure

Test Pressure (barg/psig)	
High side	Low side
28/405	19/275

- Listen for any possible leaks and check all joints with bubble spray. If any leaks are discovered, release pressure slowly from system until empty, repair leak and then restart pressure testing procedure. Never attempt to repair a leak on a pressurized system.
- A strength test should also be incorporated (to install pipework only) according to applicable standards.
- Once testing has been completed satisfactorily, release the pressure from the system gradually and safely to external atmosphere.

Evacuation and Charging



NOTICE

Moisture prevents proper functioning of the compressor and the refrigeration system. Ensure that a good quality vacuum pump is used to pull a minimum vacuum of 250 microns (0.25 torr).

Once pressure testing has been completed, the system can now be evacuated to remove air and any moisture from the piping. This can be done as follows:

- Ensure any nitrogen charge is safely released from the system.
- Connect a gauge manifold to the connections on the service valves on the condensing unit.
- Connect a vacuum pump and vacuum gauge to the system.
- Ensure all gauge manifold and service valves are open as required.
- Evacuate the system until vacuum is below 250 microns (0.25 torr).

Note: A triple evacuation procedure is recommended for all new systems or where moisture is suspected.

- Once the system is isolated and the vacuum pump is switched off, any rise in pressure indicates that either there may be a leak in the system or moisture is still

present. In this case, recheck the system for leaks, repair as necessary, and then restart the evacuation procedure. Once completed satisfactorily, the vacuum pump and vacuum gauge can be removed.

- At this point, the refrigerant charge can be added to the system as required. Refrigerants must be charged in the liquid phase. Charging liquid into the suction side of the system should ONLY be done with a metering device. Use calibrated weighing scales to record the amount of refrigerant added to the system.

Electrical

Below table lists recommended wiring sizes for the condensing unit power supply cables. These wiring sizes are valid for cable lengths up to 30m.

Table 10: Recommended wiring sizes

Model	Cable size, mm ² (from network to unit main switch)
JEHSI-033-B3-M-3	4
JEHSI-066-B3-M-3	4
JEHSI-087-B3-M-3	6

- Note: Above is just a guideline for wire size. Installer might specify cable size different from this guideline, depending on the wire material and length, system design, ambient temperature, etc.
- Cables to the condensing unit should wherever possible be routed through the cable glands supplied on the rear panel and routed through the wire bush/cable gland designated for the incoming supply at the control box casing.

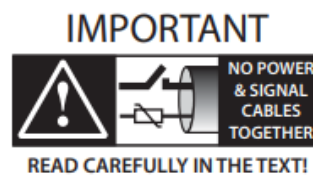

Separate power cables as much as possible from the probe and digital input cables to avoid possible electromagnetic disturbance. Never run power cables and signal

cables in the same conduits.

- Connect the mains supply to the units as per the wiring diagrams shown in **Figure 23-25**.
- Ensure that the power supply corresponds to the unit and that the power supply is stable.
- Connect power supply according to the present norm and legal requirement. Ensure that the unit is properly connected to the ground.
- The unit is equipped with a motor circuit breaker with overload protection for frequency drive. Overload protection is preset from factory and value can be found on the wiring diagram adhered on the control box cover.
- Unit equipped with manual reset high pressure switch and auto reset low pressure switch.
- If system pressure exceeds high pressure switch cut out pressure, it will immediately break the circuit to digital input "Safe Torque Off (STO)" on the drive. When the STO contact is open, the drive stops operating, bypassing the software control.

Phase Sequence for Correct Compression



NOTICE

BLDC scroll compressor requires proper phase sequence to secure correct rotation direction and therefore compression. The phase sequence has to be secured between the drive and compressor. Compressor rotation direction is not influenced by the phase sequence between network and unit drive.

Warning When Touching Unit When OFF



WARNING

Frequency converters contain DC-link capacitors that can remain charged even when the frequency converter is not powered. To avoid electrical hazards, disconnect AC mains and wait at least 5 minutes for the capacitors to fully discharge before performing any service or repair work. Failure to obey this instruction before conduct service or repair could result in death or serious injury.

The digital inputs are not a safety switch. The frequency converter is still powered even though it was cut off by digital input via alarms activation. Thus, do not remove 3 phase connections to the frequency converter, compressor connections or other power connections while the frequency converter is connected to power.

Earth Leakage Current



CAUTION

This product integrates a frequency converter which can cause ground leakage currents exceeding 3.5mA. According to IEC 61800-5-1 a reinforced Protective Earth connection must be ensured with a min. 10mm² or an additional PE wire which must at least same cross section as the mains supply wires-must be terminated separately.

This product can cause a DC current in the protective conductor. If a residual current device (RCD) is used for extra protection on the mains supply side, it must be a Type B (time delayed). The use of RCD and protective earth for the frequency converter must always follow national and local regulations.

Commissioning



WARNING

Before performing any service/maintenance work on the unit, ensure that the power supply is switched off and then wait at least 5 minutes to allow the capacitor to fully discharge. Failure to do so may result in serious injury or death.

To gain access to the electrical box, turn the mains isolator switch on the front of the unit to the OFF position, loosen the screws on the left-hand side of the door and open the door. The electrical box is located behind the front door. Remove the screws in the electrical box cover to access components.

Figure 9: Access Point

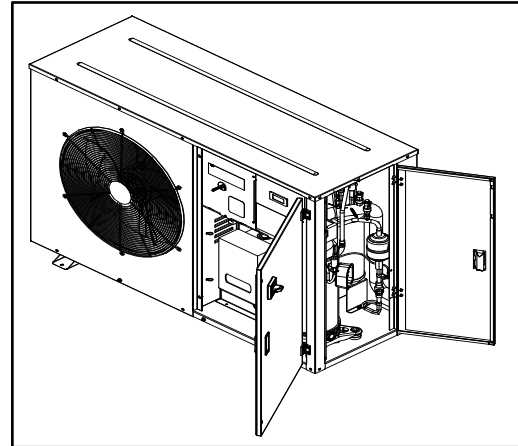

Access to Controller and LCD Display



WARNING

Only Authorized personnel are allowed to access the controller and LCD display.



NOTICE

Please wait approximately 1 minute for controller initialization after switching on the main isolator.

Pre startup checks

Before starting the condensing unit, the following checks should be carried out as a minimum:

- Check electrical supply is correct and all connections are sound.
- All moving parts are free, and guards are fitted.
- Compressor oil level satisfactory.
- LCD display cable is connected to the controller to enable settings.
- Change the required setting to suit the type of application. Else, maintain as factory default setting for medium temperature application.
- All valves are in correct operating position.
- Initial refrigerant charge through liquid line.
- Crankcase heater energized for a minimum of 12 hours before compressor start-up.
- Gauge manifold connected to both low and high sides of system.

Table 11: Factory Default Setting

Description	Factory Default Setting	Remark
Refrigerant preset on controller	R448A	Type of refrigerant available for selection: R448A, R449A, R404A
Low Pressure Switch	Cut In: 3barg, Differential: 2barg (Auto Reset)	To cut off compressor when suction pressure drops below 1 barg * Software low pressure alarm threshold 1.2barg (Cae26)
High Pressure Switch	Cut Out: 28barg, Manual Reset: 22barg	Manual reset on the cartridge type high pressure switch is required after the fault is removed.
Unit Status On/Off on keyboard	Off position	Must log in through service or manufacturer password to turn on the unit
Crankcase Heater Activation	Activated only when by regulation and/or alarm	Compressor crankcase heater will be activated when compressor off and external temperature is below 15°C. (Cag43, Cag44)
Condenser Fan Modulation	Setpoint: 16barg, differential: 3barg, Proportional. Cut In only when compressor is turned ON	Fan starts to rotate when compressor is turned ON and discharge pressure more than 13barg. Fan runs at full speed when pressure more than 19barg.



NOTICE

The unit is equipped with an electronic controller and frequency converter, which had been pre-programmed with parameters ready for use with the actual unit. Parameters for operation with refrigerant R448A is defaulted. The parameter needs to be changed if another refrigerant is to be used (Refer to Refrigerant Selection).



NOTICE

Enter password to access controller settings. Please see page 13 for different access level passwords.

Before running the unit, the controller settings for Refrigerant Selection (refer Page 13) should be checked/alterd as required:

Running the unit

- Switch unit on by controller (refer Page 14).
- Run the unit and check compressor and condenser fan operation.
- Check system pressures and temperatures, gas charge and running currents of unit to ensure correct operation.
- Check transducer / sensor readings are accurate (calibrated equipment required).

- Check compressor suction superheat. This should be between 10K and 20K in normal operating conditions.
- Final adjustment of controller settings.
- Allow the system to run for 3 – 4 hours. Check compressor oil level and top up with the correct oil type as required (see Table 2). Recheck the compressor oil level again after 24 hours operation.
- Carry out final leak test and ensure all panels/covers are fitted and screws tightened.
- Log all information along with the system model and serial numbers for future reference.
- Complete refrigerant labelling to comply with F-Gas regulations.
- Ensure that the customer / responsible person is provided with basic operating instructions and where electrical isolators are situated in case of emergency.

User Terminal Interface – LCD Display

The user terminal can be used to perform all the operations allowed by the program, display the operating conditions of the unit all the time, and set the parameters. It can be disconnected from the main board, and in fact is not required for operation.

Figure 10: LCD Display



Table 12: LCD Display Button Functions

ALARM	Displays the alarms. Press around 2 seconds to reset the alarm manually after the fault is removed.
UP	If the cursor is in the home position (top left corner), scrolls up the screens in the same group; if the cursor is in a setting field, and increases the value.
DOWN	If the cursor is in the home position (top left corner), scrolls down the screens in the same group; if the cursor is in a setting field, and decreases the value.
ENTER	Used to move the cursor from the home position (top left corner) to the setting fields, in the setting fields confirms the set value and moves to the next parameter.
PRG	Accesses the menu for selecting the group of parameters to be displayed/modified (access to the parameters is confirmed by pressing the [Enter] button).
ESC	Used to move back to previous screen/sub-menu. Continuous pressing of the ESC button will eventually return to the HOME screen.

Controller Home Screen

Start Up Screen

Following controller power-up and initialization process (approximately 1 minute), the controller home screen will appear as follows:

```
LT 08:17 10/02/21
Evaporating: -9.9barg
Condensing: -5.6barg
Actual speed: 0.0rps
Unit OFF by keyboard
```

The suction pressure, discharge pressure and compressor running rps of the unit are displayed. If Unit Off by keyboard is indicated in the lower box, then the unit is switched OFF on the controller. To switch the unit ON, follow instructions on page 14 (Switch Unit ON/OFF by Controller). Further information on the system conditions can be displayed by pressing the DOWN arrow.



NOTICE

All controller parameters are preset in the factory and are protected by password. It depends on the inserted password for different levels of accessibility.

Press "PRG" to enter screen Password management.

Password for Accessibility Level

```
Password management
Insert password: 0000
```

- User: 0000 (only can change suction line setpoint (screen Ab01, default 3.3barg) and Condensing setpoint (Screen Ab05, default: 16barg), not authorization to switch on/off by keyboard).
- Service: 1001 (access for all operation parameters, except "advanced" configuration parameter).
- Manufacturer: 9009 (access to "advanced" configuration parameters, e.g., C. Compressor-> Advanced, to change type of Refrigerant, compressor model etc).



NOTICE

To change the parameter, the unit must be in OFF mode. To access through different levels, first need to logout from existing password by scrolling to mask Ge02 Logout.

Changing Set Point

```
Suction line Ab01
User setp.: 3.3barg
Act.setp.: 3.3barg
Prop. band: 6.0barg
Integral time: 50sec
Control by: FIXED SETP.
```

1. With controller Home screen displayed, Press PRG button to go Main Menu screen and select "A. Unit Status", press ENTER and select "b. Setpoint" by DOWN button. Screen Ab01 is displayed. To adjust the setpoint, you need the cursor to be by the User setp., then use UP/DOWN buttons to adjust value and then press ENTER to confirm setting.

```
Condensing Ab05
User setp.: 16.0barg
Act.setp.: 16.0barg
Diff.: 3.0barg
Control by: PROPORTIONAL
```

2. Return the cursor to its 'home starting point' before you can move to the next screen Ab05 by pressing the DOWN button. Press ENTER until cursor point to User setp., use UP/DOWN button to adjust value. Press ENTER to confirm the setting and then ESC button repeatedly to return to Home screen.

Please note that the set point value of 16.0 bar is recommended for R448A/R449A operation.

Refrigerant Selection

*Applicable only with manufacturer password

All below steps must be accomplished if refrigerant is changed from default:

1. Press PRG to go to the main menu, select "C. Compressor" and press ENTER. Select "g. Advanced" and press ENTER. Enter screen Cag01: Refrigerant Type. Press ENTER to move cursor and UP/DOWN button to select type of refrigerant. Press ENTER for execution and press DOWN button to move to the next screen.

```
Comp.Advan. Cag01
Refrigerant type: R448A
```

2. Cag02: Select the compressor model. Refer compressor nameplate on the unit to ensure correct model is selected. Change Set Default: YES. Press ENTER for execution. Press ESC button to go back to "g. Advanced". Press ENTER and DOWN button to go to mask Cag49.

```
Comp.Advan. Cag02
BLDC settings
Motor Type: SIAM AGK66FDB-R448A
Set defaults: YES
Poles numbers: 6
Type drive: PSD1*354**
```

3. Cag49: Change Max pressure differ. admitted: 9.0bar. Press ENTER for execution.

```
Comp.Advan. Cag49
start-up pressure differential control
Max pressure differ. admitted: 9.0barg
```

4. Cag52: Start-up forced speed: 60.0rps; Max speed: 100.0rps; Min speed: 30.0rps. Press ENTER for the execution.

```

COMP.Advan. Cag52
Speed management

Start-up forced
speed: 60.0rps

Max speed: 100.0rps
Min speed: 30.0rps

```



Ensure all data on Cag02, Cag49 and Cag52 are changed accordingly if Cag01 is modified on the type of refrigerant.

NOTICE

Switch Unit ON/OFF (By Controller)

*Applicable only with service password and manufacturer password

```

LT 08:17 10/02/21
Evaporating: -9.9-barG
Condensing: -5.6barG
Actual speed: 0.0rps

Unit OFF by keyboard

```

```

Main menu 1/0E
A.Unit Status
I/O B.Inputs/Outputs
C.Compressors

```

```

Unit Status 3/3E
a.Main info
b.Setpoint
c.On/Off

```

```

On/Off Hc01
status:UnitOn

OFF ON
[ENTER] to switch unit

```

1. With controller Home screen displayed, Press PRG button to go Main Menu screen and select "A. Unit Status".
2. Press ENTER button. Screen "Unit Status" is displayed. Select "c. On/Off" and then press ENTER button.
3. Switch Unit ON by using ENTER button. Indicator pointing to ON means Unit is ON. (Press ENTER button if want switch to OFF position).
4. Press ESC button repeatedly to return to Home Screen. This should now show ON by KEY at the bottom of the screen.
5. The unit will start up following a short delay (assuming all conditions for compressor start-up are met).

Compressor Model Selection

*Applicable only with manufacturer password



NOTICE

Only one Scroll BLDC compressor controlled via Power+ inverter can be selected. The type of compressor is chosen in Compressors-> Advanced (Cag02).



NOTICE

The BLDC compressor is managed via Modbus and works only if connected to an inverter drive. If there is no communication with the driver, the compressor will not be able to operate.

- If the controller is replaced, the new system can be configured manually under the menu Compressors -> Advanced-> screen Cag02. Select YES for Set defaults and press ENTER.

- Controller and drive must be powered and connected via serial; the address of power+ must be 1 (default).
- The type of compressor should be selected from the list of available compressors under **Application: Low Temperature**; the number of motor poles and the correct model of drive are defined automatically.

Table 13: List of Compressor in Controller

Motor Type (R448A)	Motor Type (R449A)	Motor Type (R404A)
SIAM AGK33FDA-R448A	SIAM AGK33FDA-R449A	SIAM AGK33FDA-R404A
SIAM AGK66FDB-R448A	SIAM AGK66FDB-R449A	SIAM AGK66FDB-R404A
SIAM AGK87FDC-R448A	SIAM AGK87FDC-R449A	SIAM AGK87FDC-R404A

- If the model of drive is the same model or larger than the drive selected based on the type of BLDC compressor, the default values can be written, and controller can control the compressor. Otherwise, the message "Not compatible" will be shown.

Compressor Operation

Envelope management

- The compressor working zone in the software is defined based on the following measurements:
 - Condensing pressure
 - Evaporation pressure
 - Discharge temperature
and compares these against the compressor envelope. The controller manages the demand for capacity sent to the drive, in a controlled manner to maintain the compressor operating conditions within the limits of pressure and temperature defined by the manufacturer (zone 1a-1b). The actions to keep the compressor within the operating zone specified by the manufacturer are:
 - Decrease in acceleration or deceleration, when compressor operation approaches the limits, until holding the speed when operation is at the limit.
 - Speed reduction when operation is beyond the high condensing pressure or high compression ratio limits, to return within the permitted operating zone.
- When compressor operation remains too long in a zone outside of the envelope, an alarm is generated (mask Cag55, default 60sec). The zone number and description are shown on the alarm mask. During start-up, when the compressor operates at a fixed speed for the minimum ON time, this alarm is disabled.
- The discharge temperature alarm is always active.
- The following zones are defined:
 1. Inside the envelope (a, b with different maximum discharge temperature)
 2. High compression ratio
 3. High condensing pressure
 4. High current
 5. High evaporation pressure
 6. Low compression ratio
 7. Low pressure differential
 8. Low condensing pressure
 9. Low evaporation pressure

Figure 11: Compressor Operating Zone

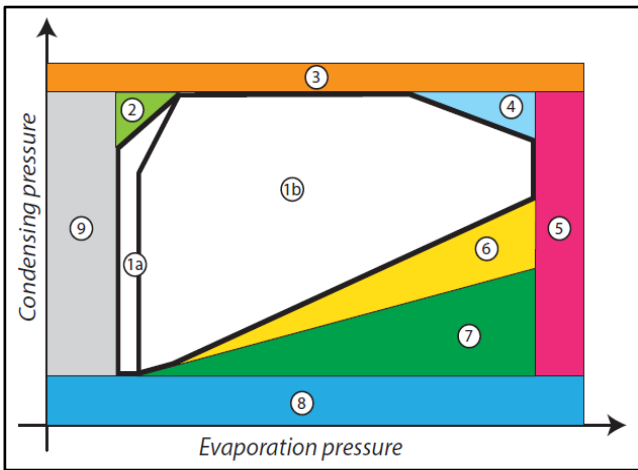

Pressure differential during start-up

- The BLDC compressor **cannot start if the pressure differential is greater than 9.0barg**. This limit depends on the maximum current delivered by the inverter. As soon as the pressure differential falls below the minimum threshold, the compressor can start.
- The corresponding parameters are in loop: Compressors -> Advanced -> mask Cag49:
- When the pressure differential is 8.5barg (fixed value), the compressor is ready to start.

```
Comp.Advan. Cag49
Start-up Pressure
differential control

Max pressure differ.
admitted: 9.0barg
```

Inverter compressor start-up:

Compressor is managed to start-up by adapting operating speed to guarantee that the desired conditions and excellent lubrication are reached very quickly. For this reason, when starting the compressor is operated at a settable fixed speed (Cag52) for the minimum ON time. During this stage, the out-of-envelope alarm is disabled, but speed control remains active if approaching or exceeding zone 2 (maximum compression ratio), 3 (maximum condensing pressure) or 4 (current limit).

If 45 seconds after compressor start-up, the pressure differential is less than 0.2barg higher than the value measured at start-up, the controller stops the compressor and generates a "No compressor start-up" alarm. This alarm is automatically reset, and the controller tries to start the compressor five times after a 30 second delay. After the fifth attempt, the alarm is no longer automatically reset.

Figure 12: Compressor Startup Curve

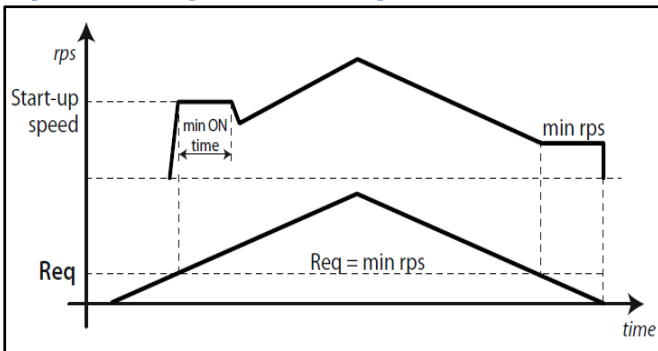

The corresponding parameters are in loop: Compressors -> Advanced -> masks Cag50, Cag51, Cag52:

```
Comp.Advan. Cag50
Start-up failure
control

Pressure difference
min.variation: 0.2barg

Control period: 45s

Comp.Advan. Cag51
Start-up failure
control

Restart delay: 30s

Max retry number: 5

Comp.Advan. Cag52
Speed management

Start-up forced
speed: 60.0rps

Max speed: 100.0rps

Min speed: 30.0rps
```

Minimum pressure differential for lubrication

The min. pressure differential threshold for correct lubrication is related to the type of BLDC compressor and cannot be modified. The low-pressure differential alarm is generated when the difference between condensing pressure and evaporation pressure (DeltaP) remains below the limit defaulted for a set time, and consequently excellent lubrication is not guaranteed. The alarm stops the compressor and is reset automatically. The alarm is not active during defrosting.

The corresponding parameters are in loop: Compressors -> Advanced-> mask Cag55:

```
Comp.Advan. Cag55
Envelope control

Out of envelope
alarm timeout: 60s

Low pressure diff.
alarm timeout: 60s
```

Times

Time management includes a minimum On time, a minimum Off time and a minimum time between two consecutive starts. These parameters can be modified under Compressors -> Configuration -> mask Caf35:

```
Comp.Conf19. Caf35
Compressor controlled
by BLDC, timings

Min on time: 180s

Min off time: 180s

Min time to start
same compressor: 370s
```

Figure 13: Times Control for Compressor Startup

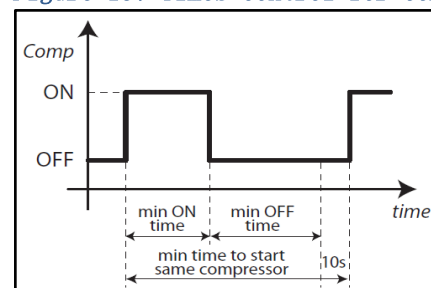

Compressor Control

Control can be proportional or proportional + integral (P, P+I). The corresponding parameters are in loop: Compressors -> Regulation -> mask Cab14.

```
Comp.Regul. Cab14
PI Press. regulation
Differential: 6.0barg
Integral time: 50sec
```

The set point is in the center of the band. Proportional control is illustrated in **Figure 14**.

Figure 14: Proportional Control

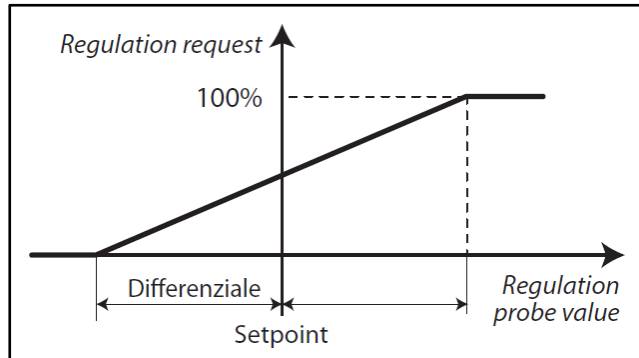

With proportional + integral control, the integral time is summed to the effect of proportional control, giving a null control error in steady operation. This type of control is illustrated in **Figure 15**.

Figure 15: Proportional + Integral Control

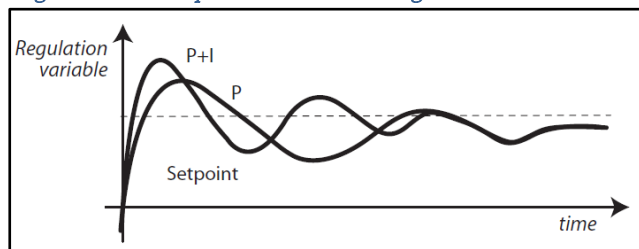

The integral action depends on time and the deviation from the set point. The integral time represents how fast integral control is implemented:

- Low values bring fast actions yet more instability
- High values bring slower actions and more stability

The values should not be set too low, to avoid system instability. Two types of control can be set, in loop Compressors -> Regulation -> mask Cab01

- Fixed set point: Default
- Floating set point: Only available by exploiting serial communication with the evaporators. Serial communication allows information to be exchanged in real time between the controller and the MPXPRO devices.

AC Fan Speed Modulation

One of the AC fans is controlled by a phase cut modulating device based on pressure input. The fan speed control is factory preset with a ± 3.0 barg differential setting. With this setting, the fan operation is as follows:

The meaning of the parameters that are associated with modulating device on masks Db03, Db07, Db04, Db06 and Dg02 are illustrated in the following graph.

```
Cond.Regul. Db03  Cond.Regul. Db07  Cond.Regul. Db06
Pressure regulation  Pressure regulation  Pressure regulation
Setpoint: 16.0barg  Differential: 3.0barg  Reg.type: PROPORTIONAL
Integral time: -s

Cond.Regul. Db04  Cond.Regul. Dg02
Fans work only when  Modulate device confi
compressor works: YES  Min out value: 4.5U
Delay after compr.OFF:  Max out value: 10.0U
Restart with compr.  Min power refer.: 0%
request: NO  Max.power refer.: 100%
```

The fan under FSC control will start at 100% speed for approximately 5 seconds before starting modulates between 45% ~ 100% of full fan speed.

Figure 16: Fan Control Curve

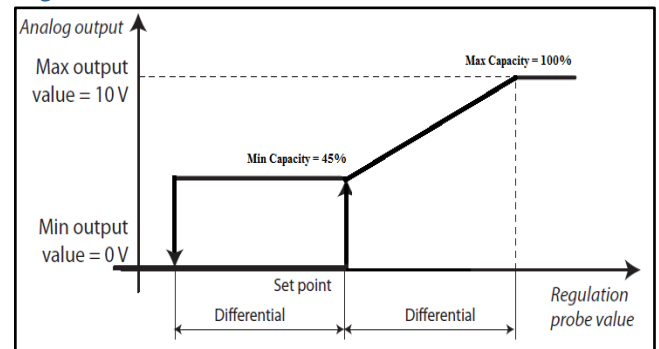

- Fan control can be switched to be controlled by external temperature probe if fault discharge pressure transducer. Associated parameter to be changed on masks: Dg14, Dg15.
- Recommended fan settings to gain higher energy efficiency as published in the Ecodesign data sheets are as follows:

Table 14: Fan Settings for Ecodesign Data

Refrigerant	R448A/R449A
Setpoint limits (Db02)	Minimum: 10barg; Maximum: 28barg
Setpoint (Db03)	13.5barg
Cut off enable (Db05)	No
Pressure Regulation Differential (Db07)	5.5barg

Mechanical Safety Pressure Switch

Mechanical high-pressure switch will cut out the STO connection on the drive to stop the compressor when discharge pressure is higher than the cut-out pressure of the manual reset cartridge type pressure switch: cut out 28barg/cut in 22barg.

- Once tripped by high pressure switch, it will create Alarm: ALW25: A1. Power+ and ALC01: Compressor1 alarm1. High pressure switch needs to be manual reset by access to the part from hinged right door (for JEHSI-033-B3-M and JEHSI-066-B3-M) and hinged front top door (for JEHSI-087-B4-M).
- Alarm ALB04 High cond. Press. is only triggered by high pressure transducer through setting in Mask De02

Condenser high pressure – threshold: 28bar; Condenser high pressure - alarm diff: 7bar; Condenser low pressure - alarm delay: 5s. To reset ALB04 alarm, remove the fault and hold down button ALARM until no active alarm appears.

Low pressure alarm could be either triggered by pressure switch or low-pressure transducer.

- When compressor turns off by activation of force off, “Forced Off” only shows in moment on info screen and no logging on alarms history.
- When setting of Mask Cae26 Suction low pressure alarm – threshold: **1.2bar**, Cae27 turn off compressor: **NO**. Alarm history will record **ALB16** low pressure alarm if system suction pressure falls below 1.2bar for delayed time set, without turning off compressor.
- If alarms triggered by low pressure switch. Alarm **ALB01** Com. Dig. Low press. will be logged in history. Default setting: semiautomatic reset 5/60min. Manual reset by holding down on the button “ALARM” until active alarm is clear, is required on the 5th times of this alarm occur in an hour. Low pressure setting had been configured in such a way that it is the first device to cut in and last device to cut out the system.



NOTICE For standalone application, compressor is force off at threshold value set in Mask Caf95 (2.5bar) to avoid recycling pump down. When the setpoint in Mask Cab03 is set lower than 2.7bar, threshold value in Mask Caf95 needs to be adjusted to avoid unnecessary unit trigger off. Do not adjust the suction low pressure alarm – threshold in Mask Cae26.

High Discharge Temperature Management

- The envelope of a BLDC compressor is also limited by high discharge temperature. If the discharge temperature continues to rise, a safety algorithm will be activated to gradually reduce it. The corresponding parameters are under submenu: Compressors - >Advanced -> mask Hb02, Hb03, Fdb04.
- Near the limit value, compressor speed will start slowing, until stopping on reaching the alarm with the high temperature alarm is activated. The alarm is reset manually.

Figure 17: Discharge Temperature Management

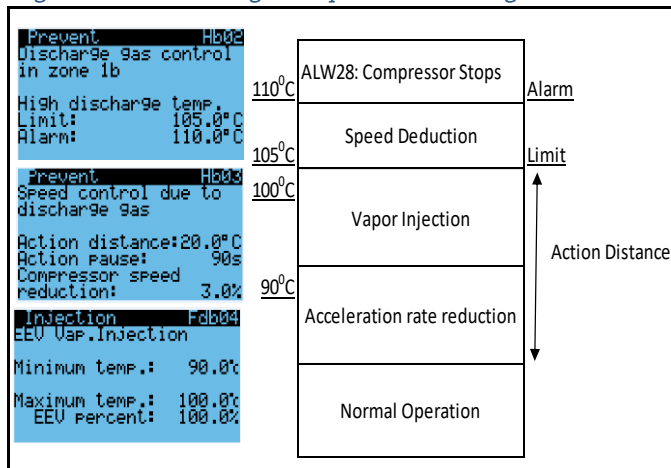

Note: EEV Vapor Injection not applicable to *-M-3* models

Speed control based on discharge temperature (Hb03):

- Speed reduction: 3% of max. speed, e.g., if max. speed is 100rps. 3rps every 90s; 3rps every 1°C
- Compressor stopping at high temperature alarm.

EEV vapor injection control based on (Fdb04):

- SH if T_{disch.} < min. temp
- T_{disch} if T_{disch.} > min. temp limit, opening to maximum % at max. temperature limit.

System Charge



NOTICE Never start the compressor under vacuum. Ensure an adequate liquid charge has been introduced to the high side of the system before starting to ensure a minimum operating pressure on the suction side of 0.5 bar is maintained, otherwise overheating of the scrolls and subsequent damage may occur. Refrigerant blend must be charged in liquid form to avoid change of chemical properties.

Condensing unit must not run, and service valves must be closed for initial refrigerant charge. The service port on the receiver outlet rotolock valve (liquid line) can be used for initial charge. Charge refrigerant as close as possible to the nominal system charge (will vary depending on the tube size and lengths) before the compressor with all service valves turn to OPEN position.

Compressor Charge Limit = 6kgs

For the adjustment of refrigerant charge until the installation reaching a level of stable nominal working condition, slowly throttling liquid in through schrader valve on the suction service valve. Charge system until reaching suction superheat 6~12K at desired evaporating temperature. Suction superheat, suction, and condensing pressures (temperatures) could be found on the info screen of the controller. While optimizing charging, ensure oil sight glass doesn't start foaming.

A proper refrigerant charge should secure stable condition at minimum and maximum heat load within the limits of the condensing unit's application envelope.

- Minimum heat load conditions, which occurred during winter. Condenser should not be flooded by liquid refrigerant, receiver and liquid line should be able to contain remaining charge at this condition.
- Maximum heat load conditions, which occurred during summer. All evaporators are working with maximum air/liquid flow via evaporators and refrigerant charge should be enough to feed to all evaporators.



NOTICE Refrigerant charge by judging the liquid sight glass does not guarantee as 100% correct way.

To avoid system overcharging, which can cause higher energy consumption and low compressor sump superheat.

Compressor sump superheat = temperature of (compressor shell-bottom at 30mm above foot shell – condensing saturated vapor at that time)

- Ensure compressor sump superheat more than 10K.

The system approximate maximum charge can be calculated as below:

Approximate Maximum Charge = (Receiver Volume + Internal volume of Liquid Line) * 0.9

When the compressor operates under stabilized conditions, the oil level must be visible in the sight glass (floating ball). Foam filling the oil sight glass indicates presence of large concentration of liquid to the compressor.

No additional oil is required for installation with good oil returns, line runs up to 30m. Additional oil might be required if lines exceeded 30m, with minimum oil level must not lower than 1/4 of sight glass. Top-up the oil while compressor is idle, via suction schrader connector with a suitable pump.

Pipe Size Selection



NOTICE

Do not assume that the suction/liquid connections sizes on the condensing unit are the correct sizes to run your interconnecting refrigeration pipes.

As a piping design concept, convenience store application will operate at part load condition. It is a concern that too big suction cross section area will cause refrigerant do not obtain sufficient velocity to carry oil returned to compressor.

Table 15 provides a guideline for quick selection of suction pipe size.

To find optimum suction pipe size for oil return.

Example:

1. Calculate % of refrigerant flow for each indoor
 - Total cooling load = 6.5+6.5 = 13kW = 100%
 - Flow for IDU 1 = 6.5/13 = 50%
 - Flow for IDU 2 = 6.5/13 = 50%

2. Select suction pipe size using **Table 15** based on optimum minimum speed not lower than 30rps. Refer **Figure 18** for the selected suction pipe size.

3. Conclusion: Minimum running speed of compressor for oil return with this combination of piping is 21 rps.

Figure 18: Suction Pipe Layout for 1 outdoor to 2 indoors

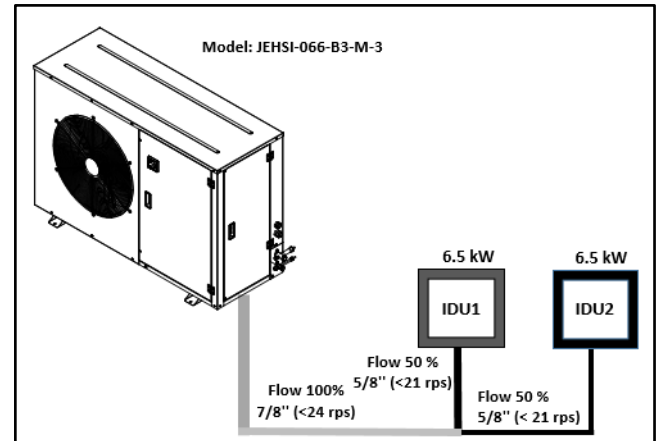

Table 15: Suction Pipe Size Selection

Model	% Refrigerant flow	Oil return speed limited (rps) for each pipe size										
		1 3/8	1 1/4	1 1/8	1	7/8	3/4	5/8	1/2	3/8	1/4	
JEHSI-033-B3-M-3	100%			94	70	51	37	26	20	20	20	
	90%			105	78	56	40	28	20	20	20	
	80%			118	88	62	44	31	20	20	20	
	70%				100	71	50	34	22	20	20	
	60%				118	84	57	39	25	20	20	
	50%					101	68	45	29	20	20	
	40%						85	54	34	20	20	
	30%							114	72	43	24	20
	20%								109	61	34	20
JEHSI-066-B3-M-3	100%		57	44	34	24	20	20	20	20	20	
	90%		75	49	37	27	20	20	20	20	20	
	80%		117	55	41	30	21	20	20	20	20	
	70%			71	47	34	24	20	20	20	20	
	60%				55	40	28	20	20	20	20	
	50%				85	47	33	21	20	20	20	
	40%					59	40	26	20	20	20	
	30%						53	34	20	20	20	
	20%							51	30	20	20	
JEHSI-087-B4-M-3	100%	52	42	32	25	20	20	20	20	20	20	
	90%	58	46	36	27	20	20	20	20	20	20	
	80%	64	52	40	30	22	20	20	20	20	20	
	70%	72	59	46	34	25	20	20	20	20	20	
	60%	82	67	53	40	29	20	20	20	20	20	
	50%	97	78	63	47	34	24	20	20	20	20	
	40%	118	95	76	59	43	29	20	20	20	20	
	30%			97	75	56	39	25	20	20	20	
	20%				108	80	57	37	22	20	20	
10%						105	71	42	22	20		

Controller Settings

The controller inside the condensing unit had been preset from factory, in accordance to the following lists:

Note: In case controller is replaced, it shall be checked to ensure correct refrigerant selection and compressor model (Refer Procedure Refrigerant Selection).

Table 16: Controller Default Settings

Mask Index	UoM	Type	Channel	Min	Max	Offset
Analog Input						
Bab01	barg	0-5V	B1	0	17.3	0
Bab05	°C	NTC	B3			0
Bab07	barg	0-5V	B2	0	34.5	0
Bab15	°C	NTC	B8			0
Bab29	°C	HTNC	B4			0
Digital input		Logic				
Baa00		NC	ID01			
Baa01		NC	-			
Baa02		NO	ID03			
Analog Output						
Bad01		PWM (0-10V)	1			
Digital Output						
Bacbt		NO	DO6			
Bacen		NO	DO5			
Baceq		NO	DO8			
Bacev		NO	DO3			

C- COMPRESSOR

Mask Index	Variable Description	Default Setting	UoM
Cab01	Regulation mode		PRESSURE
Cab01	Regulation type		FIXED SETPOINT
Cab02	Setpoint limits - Minimum	1.4	barg
Cab02	Setpoint limits - Maximum	5.5	barg
Cab03	Setpoint	3.3	barg
Cab14	PI press regulation - Differential	6	barg
Cab14	PI press regulation - Integral time	50	s
Cae24	Suction high pressure alarm		ABSOLUTE
Cae24	Suction high pressure alarm - threshold	16.0	barg
Cae25	Suction high pressure alarm diff.	1.0	barg
Cae25	Alarm delay	5	s
Cae26	Suction low pressure alarm		ABSOLUTE
Cae26	Suction low pressure alarm - threshold	1.2	barg
Cae27	Suction low pressure alarm diff.	0.8	barg
Cae27	Alarm delay	10	s
Cae27	Switch OFF comp.	NO	
Caf18	Start-up pressure differential control		DELTA PRESSURE
Caf35	Compressor Controlled by BLDC, timings - Min on time	180	s
Caf35	Compressor Controlled by BLDC, timings - Min off time	180	s
Caf35	Compressor Controlled by BLDC, timings - Min time to start same compressor	370	s
Caf95	Compressor controlled by BLDC, force off - Enable	YES	
Caf95	Compressor controlled by BLDC, force off - Threshold	2.5	barg
Caf95	Compressor controlled by BLDC, force off - Differential	0.1	barg
Caf95	Compressor controlled by BLDC, force off - Delay	5	s

Mask Index	Variable Description	Default Setting	UoM
Cag01	Refrigerant type	R448	
Cag02	BLDC setting - Motor Type		
Cag02	BLDC setting - Set defaults		NO
Cag03	Request in case of regulat. Probes fault:	50	%
Cag43	BLDC settings - Crankcase heater		COMP. OFF
Cag43	BLDC settings - Crankcase current	24	%
Cag43	BLDC settings - STO alarm management		MAN. RESET
Cag44	Crankcase heater Ambient temp control - Enable	YES	
Cag44	Crankcase heater Ambient temp control - Threshold	15.0	°C
Cag44	Crankcase heater Ambient temp control - Differential	1.0	°C
Cag49	Start-up pressure differential control - Max pressure differ. Admitted	9.0	barg
Cag50	Start-up Failure control - Pressure difference min. variation	0.2	barg
Cag50	Start-up Failure control - Control period	45	s
Cag51	Start-up Failure control - Restart delay	30	s
Cag51	Start-up Failure control - Max retry number	5	
Cag52	Speed management - Start-up forced speed	60	rps
Cag52	Speed management - Max speed	100	rps
Cag52	Speed management - Min speed	30	rps
Cag53	Speed management - Deceleration rate	1.6	rps/s
Cag53	Speed management - Acceleration rate	1.0	rps/s
Cag53	Speed management - Switch-off rate	2.0	rps/s
Cag54	Envelope control - Speed reduction rate	0.8	rps/s
Cag54	Envelope control - Min speed admitted	20.0	rps
Cag55	Envelope control - Out of envelop alarm timeout	60	s
Cag55	Envelope control - Low pressure diff. alarm timeout	60	s

D - CONDENSER

Db02	Setpoint limits - Minimum	10.0	barg
Db02	Setpoint limits - Maximum	28.0	barg
Db03	Setpoint	16.0	barg
Db04	Fans only work when compressor works		YES
Db04	Delay after compressor OFF	0	min
Db04	Restart with compressor request		NO
Db05	Cut-Off enable		NO
Db06	Pressure regulation - reg type		PROPORTIONAL
Db06	Pressure regulation - Integral time	-	s
Db07	Pressure regulation - differential	3.0	barg
De01	Condenser pressure high alarm		ABSOLUTE
De01	Condenser high pressure - alarm delay	5	s
De02	Condenser high pressure - threshold	28.0	barg
De02	Condenser high pressure - alarm diff	7	
De03	Condenser pressure low alarm		ABSOLUTE
De03	Condenser low pressure - alarm delay	5	s
De04	Condenser low pressure - alarm diff	1.0	barg
De04	Condenser low pressure - threshold	6.0	barg
Dg01	Modulating speed device		PHASE CUT CONTROL
Dg02	Min out value	4.5	V
Dg02	Max out value	10	V
Dg02	Min power ref	0	%
Dg02	Max power ref	100	%
Dg03	Rising time	5	s
Dg03	Falling time	5	s
Dg03	Num. control fans	1	

Alarm Settings

The alarms below are in ascending order of priority. When there is any alarm, the alarm code will be displayed on the main screen and the alarm LED will be on or blinking.

Table 17: List of Alarm Code

Alarm Code	Display description	Reset	Delay	Alarm relay	Action
ALU02	Regulation probe(s) missing	Automatic	Not present	Not present	Shutdown Unit
ALA01	Discharge temperature probe broken or disconnected	Automatic	60 s	R2	Related functions disabled
ALA02	Condenser pressure probe broken or disconnected	Automatic	60 s	R1	Related functions disabled
ALA03	External temperature probe broken or disconnected	Automatic	60 s	R2	Related functions disabled
ALA24	Suction pressure probe broken or disconnected	Automatic	60 s	R1	Related functions disabled
ALA25	Suction temperature probe broken or disconnected	Automatic	60 s	R2	Related functions disabled
ALA46	Vapor injection pressure probe broken or disconnected	Automatic	60 s	R1	Related functions disabled
ALA47	Vapor injection temperature probe broken or disconnected	Automatic	60 s	R1	Related functions disabled
ALB01	Low common suction pressure by pressostat Num.autom.reset: /in min	Semiautomatic	5/60min	R1	Shutdown compressor
ALB02	High common condensing pressure by pressostat	Automatic	0 s	R1	Shutdown compressor
ALB03	Low condenser pressure alarm	Automatic	5 s	R1	Fan Forcing at 0%
ALB04	High condenser pressure alarm	Automatic	5 s	R1	Fan Forcing at 100% (5 min.) and shutdown compressor
ALB15	High suction pressure alarm	Automatic	5 s	R1	-
ALB16	Low suction pressure alarm	Automatic	10 s	R1	-
ALC01	Alarm 1 compressor 1:	Automatic	0 s	Config.	Shutdown compressor
ALG01	Clock board error	Automatic	-	R2	Related functions disabled
ALG02	Extended memory error	Automatic	-	R2	Related functions disabled
ALT01	Compressors working hours	Manual	-	Not present	-
ALT19	DSH Low Liquid flowback	Manual	60 s	R1	Shutdown compressor
ALW24	Power+ n° Device Offline	Semiautomatic	2 s	R1	Shutdown compressor
ALW25	Power+ n°	Semiautomatic	Not present	R1	Shutdown compressor
ALW26	Compressor start failure (tempt.: / max.:)	Semiautomatic	Not present	R1	-
ALW27	Envelope alarm Zone: Num.autom.reset: /in min	Automatic	5/60min	R1	Shutdown compressor
ALW28	High discharge gas temperature	Automatic	10 s	R1	-

R1: serious alarm; R2: normal alarm

Note: Bcen activation (serious alarm) is based on Alarm Relay R1

Table 18: LCD Display - Alarm Status

LED	Alarm	Require Action
Steady On	Not active	Auto or manual reset
Blinking	Active	Manual reset

- **Auto reset:** An alarm condition is created but when cleared, the unit will restart automatically.
- **Manual reset:** An alarm condition is created and requires resetting manually before the unit can restart.
- **To reset alarm:** Press button ALARM on the LCD display for a few seconds.

Table 19: Details Error Code from Activation of ALW25

Code	Description	Possible Cause	Solution
1	Overcurrent	The drive has detected a current supplied that is too high due to: - sudden strong load increase; - wrong parameters values or inadequate motor.	Check the drive and compressor model and the cables.
2	Motor overload	The current supplied has exceeded the motor rated current over the maximum time accepted	Check the drive and compressor model and the cables.
3	Overvoltage	The DC voltage of the intermediate circuit has exceeded the limits envisioned due to high over-voltage peaks on the power supply network.	-
4	Undervoltage	The DC voltage of the intermediate circuit is below the limits envisioned due to: - insufficient power supply voltage; - fault inside the drive.	In the event of temporary cut-off of the power supply, reset the alarm and re-start the drive. Check the power supply voltage.
5	Drive overtemperature	The temperature inside the drive has exceeded the maximum level allowed.	Check that the quantity and flow of cooling air are regular. Check that there is not dust in the heat sink. Check the environment temperature.
6	Drive under temperature	The temperature of the drive is inferior to the minimum level allowed.	Closed metal panel to warm up the ambient where the drive is installed.
7	Overcurrent HW	The drive has detected an instantaneous current supplied that is too high due to: - sudden strong load increase; - motor cables short circuit; - Incorrect compressor model.	Check the compressor model and the cables.
10	CPU error	Loss of data in memory	Call for assistance
11	Parameter default	Execution of reset parameter default command; Parameters user setting corrupted	Set parameters again
12	DC bus ripple	Input power supply phase loss, three-phase power supply unbalance	Check the input power supply phases to the drive
13	Data communication fault	Data reception failure	Check the serial connection. Switch the drive off and back on again.
14	Drive thermistor fault	Internal fault	Call for assistance
16	Drive disabled (STO input open or de-energized)	Cable disconnected External pressure switches disconnected	Check the wiring. Manual reset high pressure switch
17	Motor phase fault	Compressor cable disconnected	Check the connections of the compressor cable
19	Speed fault	Wrong parameters values or unsuited load	Switch the drive off and back on again and check the parameters are properly set. Check the motor load.
23	STO detection error	Internal fault	Call for assistance
25	Ground fault	The drive has detected a ground current too high	Check ground insulation of the motor and wires.
26	CPU sync error 1	Overload CPU	Call for assistance
27	CPU sync error 2	Loss of data in memory	Call for assistance
28	Drive overload	The current supplied has exceeded the drive rated current over the maximum time accepted	Check the compressor model and the cables.

Service and Maintenance



NOTICE

Disconnect the mains electrical supply and wait at least 5 minutes for capacitors to fully discharge before opening the unit for service/repair.

The condensing units are designed to give long life operation with minimum maintenance. However, they should be routinely checked, and the following service schedule is recommended under normal circumstances:
The removal of the top, side and front panels ensures that all parts are accessible.

1. Compressor – Inspect at regular intervals.

- Check for refrigerant leaks on all joints and fittings. Retighten the valve cap according to **Table 20**.
- Check mountings for tightness and wear.
- Check operation of crankcase heater.
- Check electrical connections.
- Ensure that no abnormal noise or vibration is detected during the test run.
- Check the compressor oil levels and top up if required.

2. Condenser Fan Motor & Blade – Clean and inspect at regular intervals.

- Check for abnormal noise, vibration, and fan imbalance.
- Ensure that the fan motor is clean and spins freely.
- Check that the condenser fan blade is clean and free from restriction and damage/imbalance.

Note: The fan motor is pre-lubricated, and factory sealed so no maintenance is necessary.

3. Condenser Coil – Clean and inspect at regular intervals.

- Check and remove the dirt and debris between the fins using a soft brush, low pressure compressed air/inert gas or a low-pressure sprayer utilizing clean water. A suitable chemical coil cleaner may be used as required. Accumulations of dirt on the condenser face can be removed with a soft bristle hand brush. When using liquids, ensure electrical items are isolated and correctly protected.
- DO NOT USE HIGH PRESSURE JET WASHERS.

- Check and remove any obstacles which may hinder the airflow through the condenser coil.

4. Frequency Drive

- Check heat sink and internal fans freely rotating and dust free.
- Check on all electrical connections, ensuring screw terminals are correctly torqued (power terminal: Max. 1.5Nm, auxiliary terminal: Max. 0.5Nm)

5. Controls

- Check settings and operation of pressure switches.
- Check overload setting.
- Check fan speed control setting and operation.

6. Power Supply – Inspect at regular intervals.

- Check the running current and voltage for the condensing unit.
- Check the electrical wiring and tighten the wires onto the terminal blocks if necessary.

7. Refrigerant Charge (Refer Section Refrigerant Charge)

- Check the refrigerant charge by ensuring that the system is operating correctly, the pressures are as expected and that the liquid line sight glass shows a full bore of liquid refrigerant.
- Carry out a full leak test.

8. Unit decommissioning and disposal

- At the end of the unit's useful life, a suitably qualified engineer should decommission it. The refrigerant and compressor oil are classed as hazardous waste and as such must be reclaimed and disposed of in the correct manner, including completion of waste transfer paperwork. The unit components must be disposed of or recycled as appropriate in the correct manner.

8. Warranty

- The warranty as provided by J & E Hall on its products is subject to correct application, siting, and installation procedures together with subsequent recorded maintenance/servicing carried out in accordance with our recommendations. Failure to do so could result in the withdrawal of our warranty. Please go to our website for our detailed warranty terms and conditions: www.jehall.co.uk

Table 20: Tightening Torque

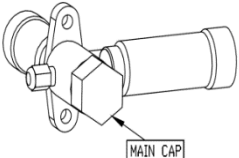
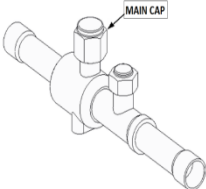
Model	Thread/Size (Tightening Torque (Nm))		
	Main Cap Service Valves	Main Cap Ball Valve	Schrader Cap 1/4" SAE, Oil Return Port, Liquid Receiver and Low-Pressure Switch
JEHSI-033-B3-M-3	Suction: M22*1.0mm (30-35 Nm) Liquid: M18*1.0mm (25-30 Nm)	M16*1.5mm (10-15 Nm)	7/16" - 20UNF (14-16 Nm)
JEHSI-066-B3-M-3	Suction: M25*1.0mm (42-47 Nm) Liquid: M18*1.0mm (25-30 Nm)		
JEHSI-087-B4-M-3	Suction: M33*1.5mm (42-47 Nm) Liquid: M25*1.0mm (25-30 Nm)		
Graphic			-

F-Gas Requirement

The models of equipment covered in this Technical Manual rely on fluorinated greenhouse gases for their functioning.

All unit models come from the factory pressurized with OFN (Oxygen Free Nitrogen) only.

In F-Gas Regulation EU 517/2014, this type of system only be able to be installed by engineers who hold an F Gas qualification.

The requirement for leak testing is based on the charge size in tonnes of CO₂ equivalent specified in below table. Starting 1st January 2017, the requirement for leak detection and maintaining system logs changes from 3kg HFC to 5 tonnes CO₂ equivalent.

Table 21: Leak Inspection Frequency

System Charge (Tonnes CO ₂ Equivalent)	Leak Inspection Frequency
3.6 to 36.0 kg R448A 3.6 to 35.8 kg R449A (5 to < 50 TCO ₂ eq)	<ul style="list-style-type: none"> At least once every year. At least once every 2 years if a fixed leak detection system is fitted.

A refrigerant charge label is supplied with each outdoor unit. The refrigerant charge for the system must be filled on the label along with the TCO₂eq value with indelible ink and must be adhered in the proximity of the product charging port.

Contains fluorinated greenhouse gases			
Ref.	GWP	Charge (kg)	TCO ₂ Eq.
R448A	1387		
R449A	1397		



Calculate TCO₂eq value from below formula:

$$\text{TCO}_2 \text{ Eq value} = \frac{\text{Refrigerant Charge (kgs)} \times \text{Refrigerant GWP}}{1000}$$

BACnet and Modbus Protocol

No serial card is required if Modbus over RS485 serial port (J11).

A Serial card is required to be plugged in the J13 connector if Bacnet over RS485 (MSTP) or IP.

Figure 19: Location of Serial Port on Controller

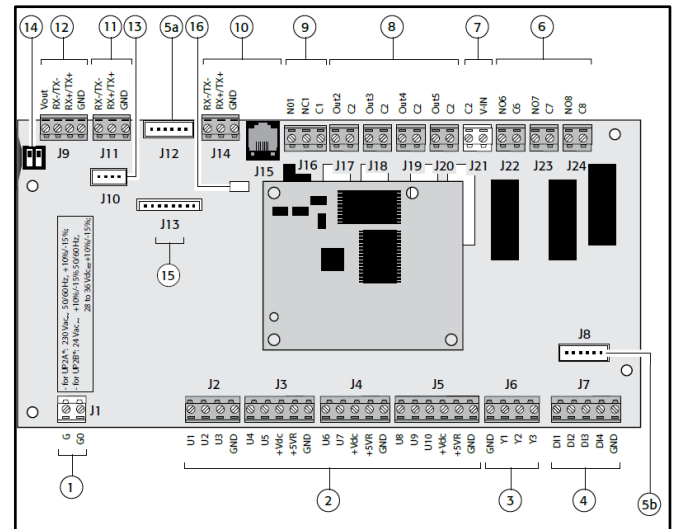

Software Update

The pCO smart key can be used to load the program into the controller. It is connected directly via the telephone connector using the cable supplied, with the power supply coming from the controller.

Figure 20: pCO Smart Key

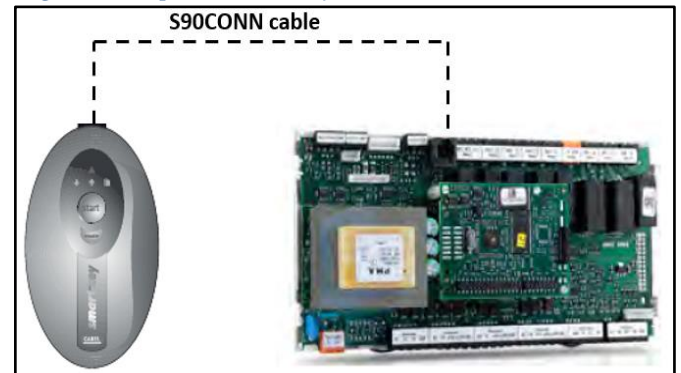

Appendix

Figure 21: Outline Drawing JEHSI-033-B3-M-3, JEHSI-066-B3-M-3

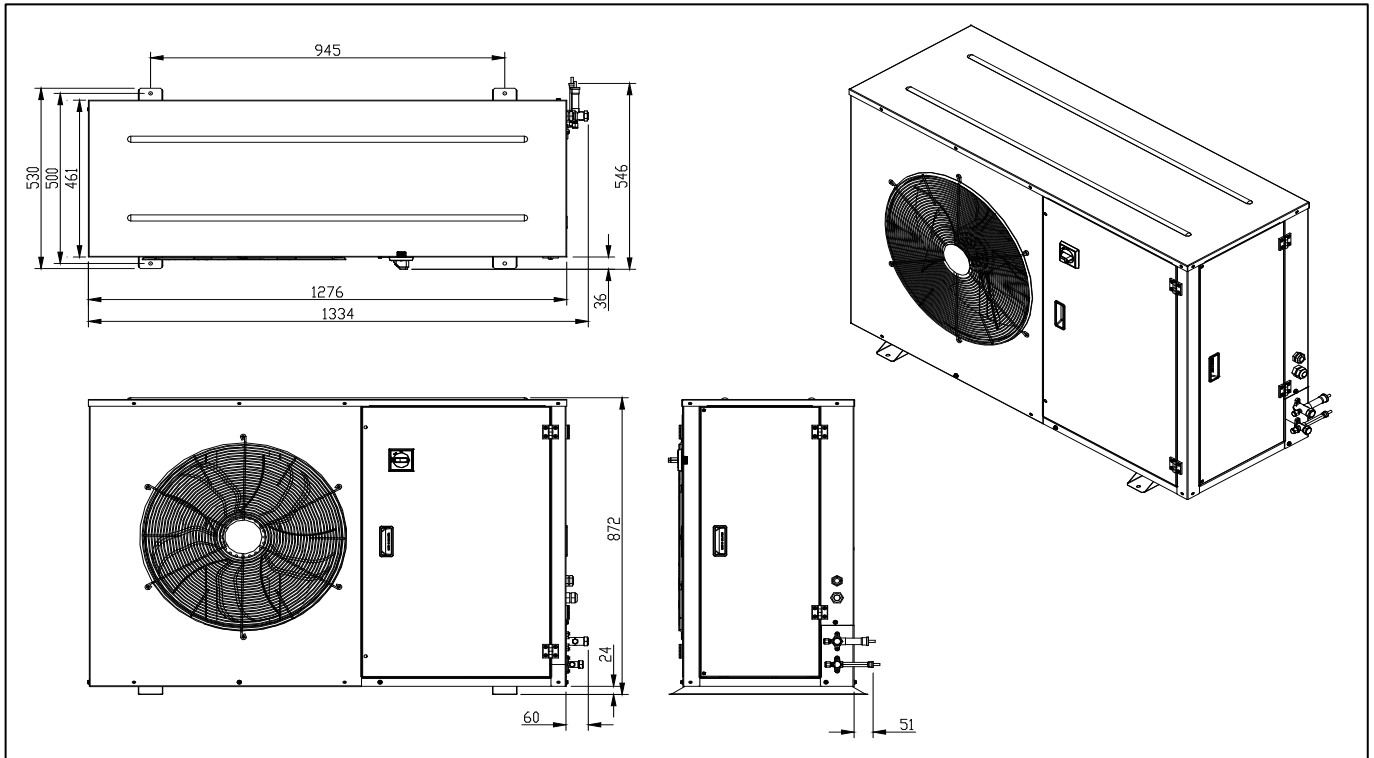

Figure 22: Outline Drawing JEHSI-087-B4-M-3

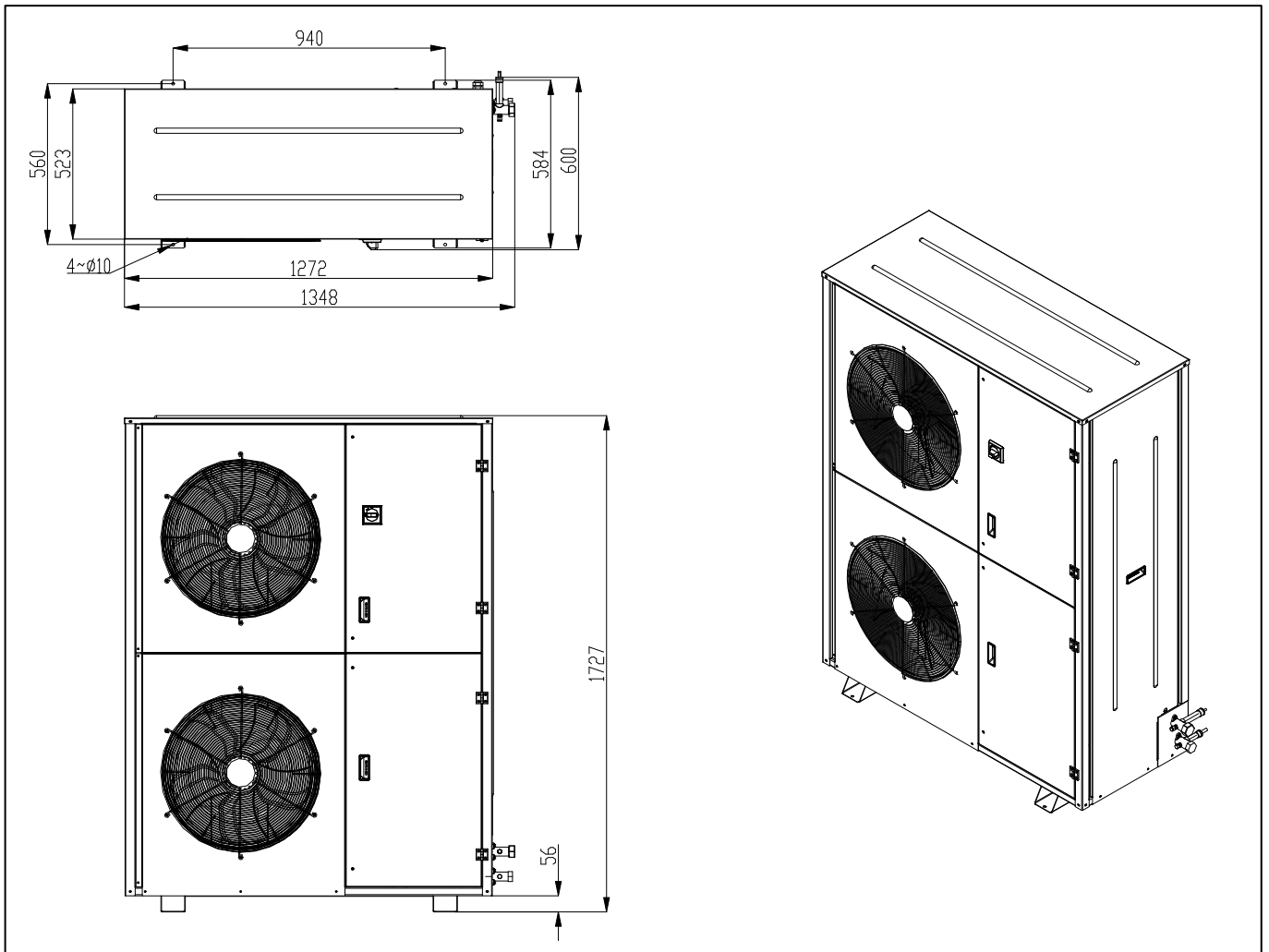

Figure 23: Wiring Diagram JEHSI-033-B3-M-3

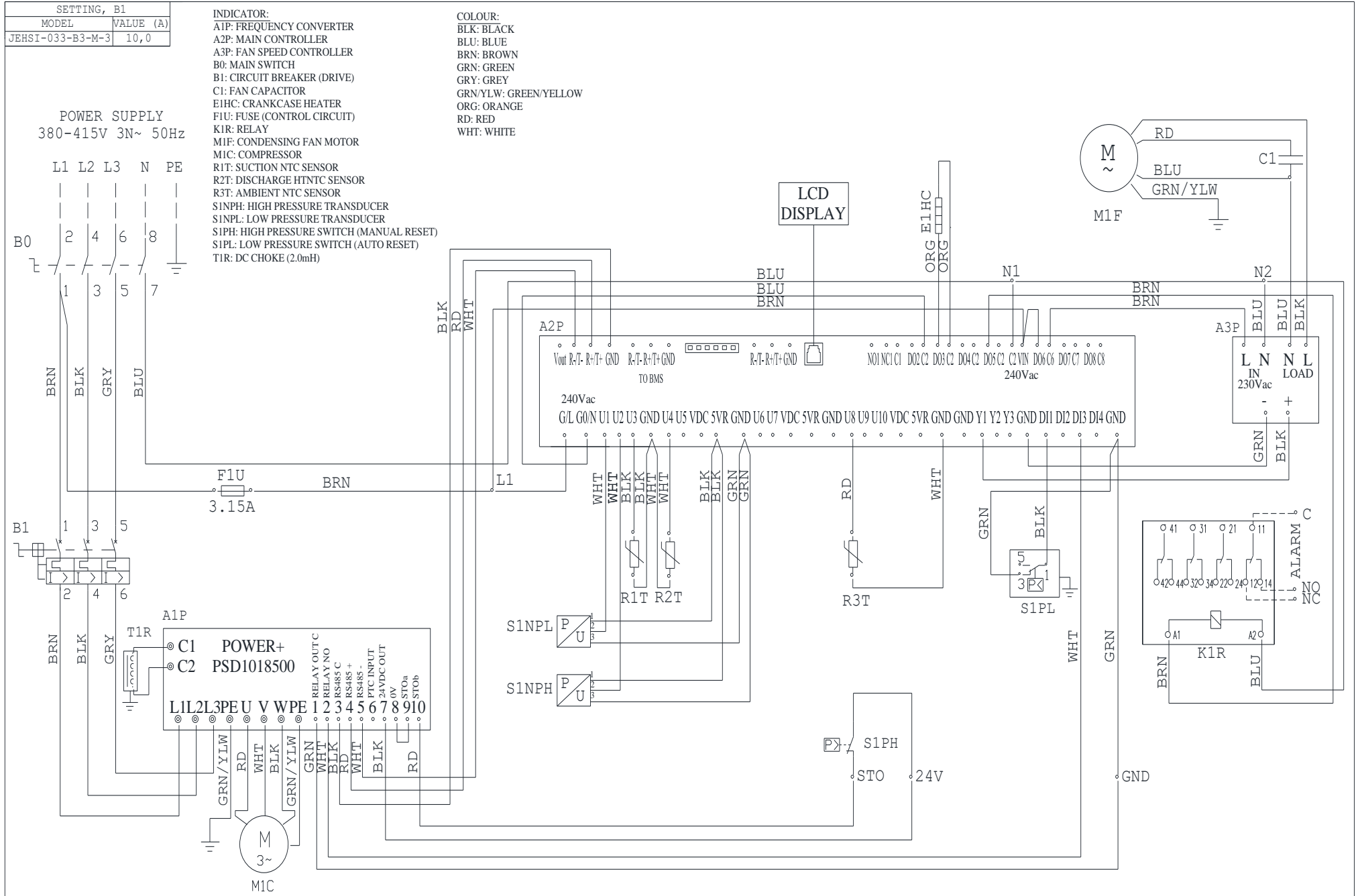

Figure 24: Wiring Diagram JEHSI-066-B3-M-3

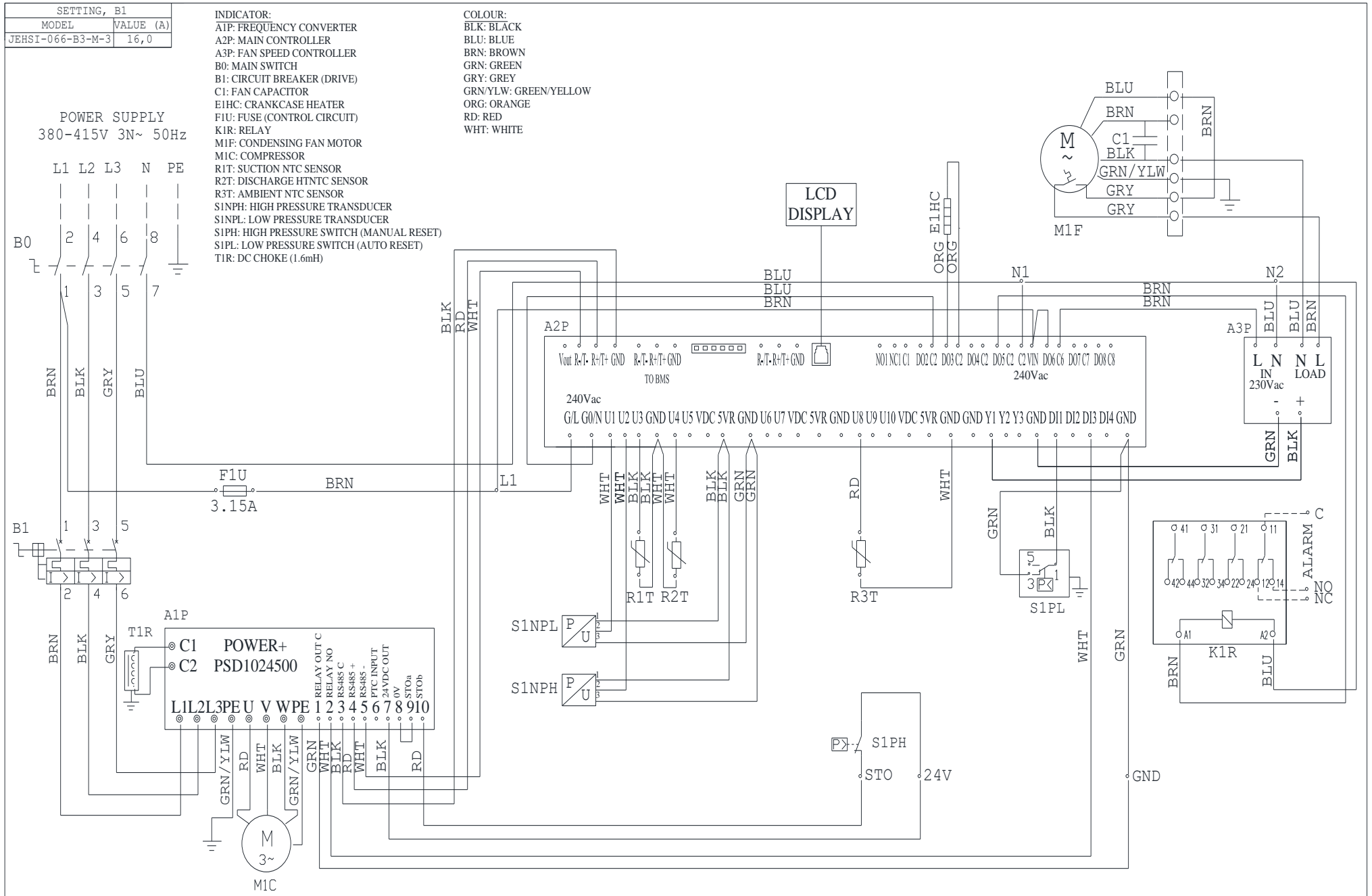

Figure 25: Wiring Diagram JEHSI-087-B4-M-3

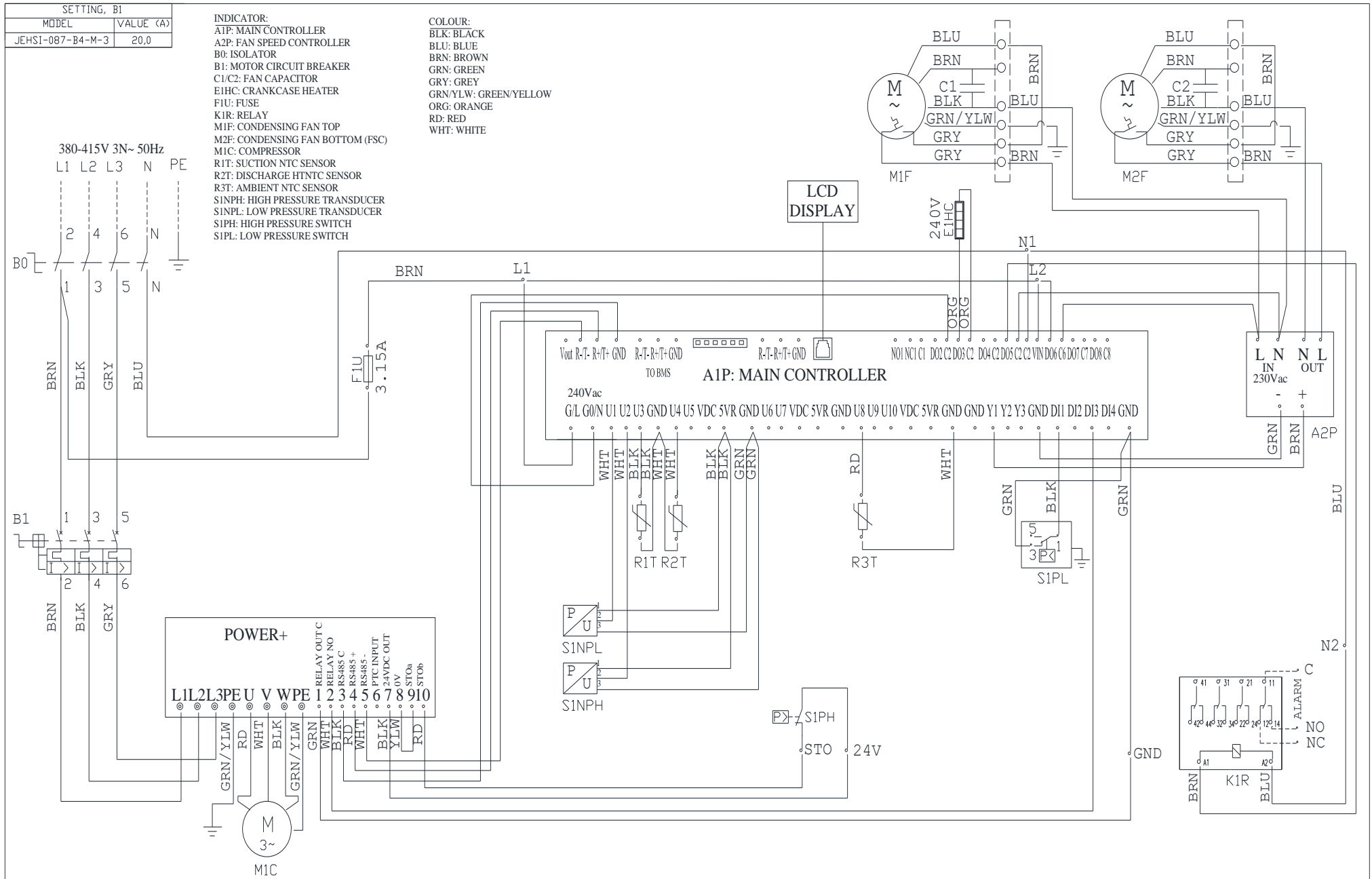

Figure 26: Declaration of Conformity

Declaration of Conformity		J & E Hall International
According to SI 2016 No. 1105 SCHEDULE 11, SI 2010 No. 26 17 SCHEDULE 1		
We:	J & E Hall International	
of:	Questor House, 191 Hawley Road, Dartford, Kent, DA1 1PU	
Declare under sole responsibility that		
The Product:	Refrigeration Condensing Unit	
Model Designations	JEHSI-033-B3-M-3 JEHSI-066-B3-M-3 JEHSI-087-B4-M-3	
Description:	Inverter Commercial Condensing Units for Medium Temperature Applications	
SI 2016 No. 1105 Conformity Assessment Procedure Followed:	Module A2	
Description of the pressure equipment constituting the assembly:		
Part description	Conformity assessment followed	
High pressure switch	Module B + D	
Compressor	Module A	
Liquid receiver	Module A / H1	
Oil separator	Module H1	
Filter drier	SEP	
Condenser	SEP	
Sight glass & Valves	SEP	
Flexible hose, System piping & Pressure accessories	SEP	
The object of the declaration described above is in conformity with the following statutory requirements and implementing measures:		
SI 2016 No. 1105	The Pressure Equipment (Safety) Regulations	
Commission Regulation (EU) 2015/1095	Commission Regulation (EU) 2015/1095 of 5 May 2015 implementing Directive 2009/125/EC of the European Parliament and of the Council with regard to ecodesign requirements for professional refrigerated storage cabinets, blast cabinets, condensing units and process chillers	
It has been designed and manufactured to the following designated standards and technical specifications:		
BS EN 60335-1	Household and similar electrical appliances. Safety. General requirements	
BS EN 60335-2-89	Household and similar electrical appliances. Safety. Particular requirements for commercial refrigerating appliances with an incorporated or remote refrigerant unit or compressor	
BS EN 13215	Condensing units for refrigeration. Rating conditions, tolerances and presentation of manufacturer's performance data	
DG-0001	Pressure Equipment	
SI 2016 No. 1105 conformity assessment was carried out by Hartford Steam Boiler UK (Approved Body Number: 2561), 9th Floor, Chancery Place, 50 Brown Street, Manchester M2 2JT, United Kingdom with Marking Permission HSB UK-22-09-004 issued.		
Signed:		
Name:	Andrew Bowden	
Position:	Managing Director	
Location:	J & E Hall Limited, Questor House, 191 Hawley Road, Dartford, Kent, DA1 1PU	
Date:	29/09/2022	
<hr/>		
Form: JEH-C6-017d-01	Questor House, 191 Hawley Road, Dartford, Kent, DA1 1PU	Page 1 of 1

Figure 27: Declaration of Incorporation



Declaration of Incorporation

According to SI 2008 No. 1597 Annex II

We: J & E Hall International

of: Questor House, 191 Hawley Road, Dartford, Kent, DA1 1PU

Declare that for below

Product Refrigeration Condensing Unit

Model Designations:

JEHSI-033-B3-M-3 JEHSI-066-B3-M-3 JEHSI-087-B4-M-3

Description: Inverter Commercial Condensing Units for Medium Temperature Applications

The following essential health and safety requirements of The Supply of Machinery (Safety) Regulations 2008 (SI 2008 No. 1597) are applied and fulfilled:

1.1.1 – 1.1.2 – 1.1.3 – 1.1.5 – 1.2.1 - 1.2.6 - 1.3.2 – 1.3.3 – 1.3.4 – 1.3.7 – 1.3.8.2 – 1.4.1 – 1.4.2.1 – 1.5.1 – 1.5.2 – 1.5.13 – 1.7.1.1 – 1.7.2 – 1.7.3 – 1.7.4

The relevant technical documentation has been compiled in accordance with Annex VII (PART 7 of SCHEDULE 2) part B of SI 2008 No. 1597.

The partly completed machinery is also in conformity with below enactments:

SI 2016 No. 1105 The Pressure Equipment (Safety) Regulations

Commission Regulation (EU) 2015/1095 Commission Regulation (EU) 2015/1095 of 5 May 2015 implementing Directive 2009/125/EC of the European Parliament and of the Council with regard to eco-design requirements for professional refrigerated storage cabinets, blast cabinets, condensing units and process chillers

The relevant information can be transmitted in electronic form in response to a reasoned request by the national authorities.

The partly completed machinery must not be put into service until the final machinery into which it is to be incorporated has been declared in conformity with the provisions of these Regulations, where appropriate.

The legal representative authorised to compile the relevant technical documentation is J & E Hall Limited, Questor House, 191 Hawley Road, Dartford, Kent, United Kingdom, DA1 1PU.

Signed:

Name: Andrew Bowden

Position: Managing Director

Location: J & E Hall Limited, Questor House, 191 Hawley Road, Dartford, Kent, DA1 1PU

Date: 29/09/2022

Figure 28: EU Declaration of Conformity

EU Declaration of Conformity		J&E Hall International
According to DIRECTIVE 2014/68/EU ANNEX IV, DIRECTIVE 2009/125/EC ANNEX VI		
We:	J & E Hall International	
of:	Questor House, 191 Hawley Road, Dartford, Kent, DA1 1PU	
Declare under sole responsibility that		
The Product:	Refrigeration Condensing Unit	
Model Designations:	JEHSI-033-B3-M-3 JEHSI-066-B3-M-3 JEHSI-087-B4-M-3	
Description:	Inverter Commercial Condensing Units for Medium Temperature Applications	
DIRECTIVE 2014/68/EU Conformity Assessment Procedure Followed:	Module A2	
Description of the pressure equipment constituting the assembly:		
Part description	Conformity assessment followed	
High pressure switch	Module B + D	
Compressor	Module A	
Liquid receiver	Module A / H1	
Oil separator	Module H1	
Filter drier	SEP	
Condenser	SEP	
Sight glass & Valves	SEP	
Flexible hose, System piping & Pressure accessories	SEP	
The object of the declaration described above is in conformity with the following Union harmonisation legislation:		
DIRECTIVE 2014/68/EU	On the harmonisation of the laws of the Member States relating to the making available on the market of pressure equipment	
Commission Regulation (EU) 2015/1095	Commission Regulation (EU) 2015/1095 of 5 May 2015 implementing Directive 2009/125/EC of the European Parliament and of the Council with regard to ecodesign requirements for professional refrigerated storage cabinets, blast cabinets, condensing units and process chillers	
It has been designed and manufactured to the following harmonised standards and technical specifications:		
BS EN 60335-1	Household and similar electrical appliances. Safety. General requirements	
BS EN 60335-2-89	Household and similar electrical appliances. Safety. Particular requirements for commercial refrigerating appliances with an incorporated or remote refrigerant unit or compressor	
BS EN 13215	Condensing units for refrigeration. Rating conditions, tolerances and presentation of manufacturer's performance data	
DG-0001	Pressure Equipment	
DIRECTIVE 2014/68/EU conformity assessment was carried out by Hartford Steam Boiler UK (Notified Body number: 2833) 28 Windsor Place, Lower Pembroke Street, Dublin 2, Ireland with Marking Permission HSB IE 22-09-003 issued.		
Signed:		
Name:	Andrew Bowden	
Position:	Managing Director	
Location:	J & E Hall Limited, Questor House, 191 Hawley Road, Dartford, Kent, DA1 1PU	
Date:	29/09/2022	
<hr/>		
Form: JEH-C6-017e-01	Questor House, 191 Hawley Road, Dartford, Kent, DA1 1PU	Page 1 of 1

Figure 29: EU Declaration of Incorporation

Declaration of Incorporation			
According to DIRECTIVE 2006/42/EC Annex II			
We:	J & E Hall International		
of:	Questor House, 191 Hawley Road, Dartford, Kent, DA1 1PU		
Declare that for below			
Product	Refrigeration Condensing Unit		
Model Designations:	JEHSI-033-B3-M-3 JEHSI-066-B3-M-3 JEHSI-087-B4-M-3		
Description:	Inverter Commercial Condensing Units for Medium Temperature Applications		
The following essential health and safety requirements of the Machinery Directive (DIRECTIVE 2006/42/EC) are applied and fulfilled:			
1.1.1 – 1.1.2 – 1.1.3 – 1.1.5 – 1.2.1 - 1.2.6 - 1.3.2 – 1.3.3 – 1.3.4 – 1.3.7 – 1.3.8.2 – 1.4.1 – 1.4.2.1 – 1.5.1 – 1.5.2 – 1.5.13 – 1.7.1.1 – 1.7.2 – 1.7.3 – 1.7.4			
The relevant technical documentation has been compiled in accordance with part B of Annex VII of DIRECTIVE 2006/42/EC.			
The partly completed machinery is also in conformity with below Directives and Regulations:			
DIRECTIVE 2014/68/EU	On the harmonisation of the laws of the Member States relating to the making available on the market of pressure equipment		
Commission Regulation (EU) 2015/1095	Commission Regulation (EU) 2015/1095 of 5 May 2015 implementing Directive 2009/125/EC of the European Parliament and of the Council with regard to eco-design requirements for professional refrigerated storage cabinets, blast cabinets, condensing units and process chillers		
The relevant information can be transmitted in electronic form in response to a reasoned request by the national authorities.			
The partly completed machinery must not be put into service until the final machinery into which it is to be incorporated has been declared in conformity with the provisions of DIRECTIVE 2006/42/EC, where appropriate.			
The legal representative authorised to compile the relevant technical documentation is TEWIS SMART SYSTEMS, S.L.U, Auguste y Louis Lumière, 26 Parque tecnológico, Paterna, Valencia, Spain.			
Signed:			
Name:	Andrew Bowden		
Position:	Managing Director		
Location:	J & E Hall Limited, Questor House, 191 Hawley Road, Dartford, Kent, DA1 1PU		
Date:	29/09/2022		
<hr/>			
Form: JEH-C6-016e-01	Questor House, 191 Hawley Road, Dartford, Kent, DA1 1PU		Page 1 of 1

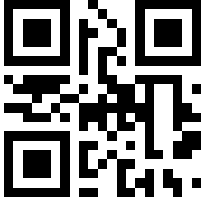

RJ0110030012639

J & E Hall Limited
Hansard Gate
West Meadows
Derby, DE21 6JN
England

Tel: + 44 (0) 1332 253400
Fax: + 44 (0) 1332 371061
Email: helpline@jehall.co.uk
www.jehall.com

Issue: 01.06.2023

