JABC-1

AMBIENT BEVERAGE COOLER

ISSUE: 01.07.2020



Contents

1. Nomenclature	3
2. Standard Product Configuration	3
3. Product Description	3
4. Specification	4
5. Box Contents	4
6. Operation	4
7. Health & Safety	5
8. Airflow Calculations	6
9. Installation	7-9
10. Commissioning	10
11. Dimensional Drawing	11
12. Wiring Diagram	12
13. Service & Maintenance	13-14
14. Troubleshooting	14
15. Certification	15

1. Nomenclature

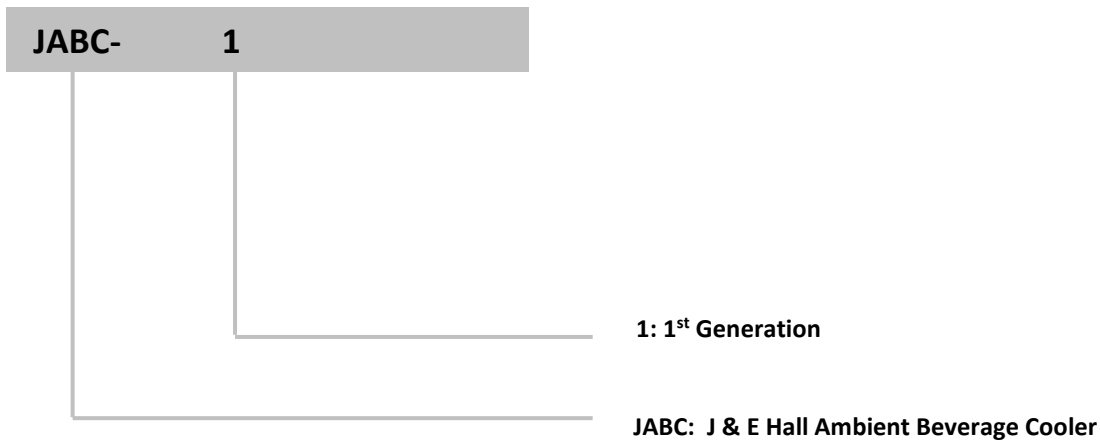

2. Standard Product Configuration

- Refrigerant free – environmentally conscious
- Washable/reusable air filter
- EBM fan motor with multi-speed capability – can be adjusted to suit room size
- Interchangeable air inlet damper location – either rear or base mounting
- Uses standard 150mm diameter ducting
- Fully pre-set controllers
- Inbuilt timer to allow cellar cooler to run for 1 hour per day (winter operation)
- Switching relay allows operation with all types of cellar coolers

3. Product Description

The JABC-1 is primarily used for cooling beer cellars. Cold air is drawn from outside by the fan through the washable air filter and distributed into the cellar space. The unit consists of a fan motor, washable filter, controllers, air damper, a pre-wired electrical control box all housed within a powder coated steel casing. Operation is via two electronic temperature controls – one an ambient controller and the other a cellar controller. Each controller has one temperature probe – the ambient probe being positioned outside by the air intake grille and the cellar probe being positioned in a suitable position within the cellar space (ideally by the main cellar cooler temperature sensor). This guideline enables users to ensure correct and safe installation, operation and maintenance of this product.

4. Specifications

Model	Fan Motor		Speed	Air Flow (m ³ /h)	Sound dB(A) @ 1m
	Type	Max Current (A)			
JABC-1	D2E146-HT5902	1.28A	4	684	69.8
			3	576	65.0
			2	468	56.4
			1	252	43.8

Model	Overall Dimension (mm)			Mounting Dimensions (mm)		Dry Weight (kg)
	W	D	H	W	D	
JABC-1	349	381	484	(Refer drawing- Page 8)		12

5. Box Contents

The following items are included:

- 1no. Ambient Cooler
- 1no. 2m mains supply cable (without plug)
- 2no. Bracket supports
- 2no. M5 screws
- 1no. Fixing hole template
- 2no. Cable glands (1no. M20 & 1no. M12)
- 1no. Technical Manual

Please Note: An installation kit is available separately which includes the following items:

- 1no. 500mm length of 150mm Ø plastic ducting
- 1no. External air grille
- 2no. Internal door grilles
- 1no. Spare air filter

6. Operation

The JABC unit is designed to operate when the external ambient temperature is 8°C or below and the cellar temperature rises above its setpoint of 10°C. The JABC fan motor will draw external cool air into the cellar – passing through the air filter and cooling the space until the set temperature of 10°C is reached. If the cellar temperature continues to rise with the JABC unit running, at 13°C the main cellar cooler unit will cut in and run along with the JABC to provide additional cooling until the setpoint temperature is reached. At this point, both the JABC and the main cellar cooler will cut off. The JABC unit will not operate if the external ambient temperature is above 8°C. At external ambient temperatures of above 8°C, only the main cellar cooler system will operate.

The JABC unit is designed to be the main control for the cellar temperature, utilizing both external air when available and the main cellar cooler as required. The main cellar cooler controller should be set to the same operating temperature as the JABC unit.

An inbuilt timer within the controller allows the main cellar cooler to run for one hour every 24 hours. This ensures that the main cellar cooler will still run during winter periods.

7. Health and Safety

Important Note:

Only qualified and authorized personnel, who are familiar with refrigeration systems and components including all controls, should perform the installation and start-up of this equipment. To avoid potential injury, use care when working around sharp edges of metal cabinets. All electrical wiring should be installed in accordance with all applicable codes, ordinances and local by-laws. No work should be undertaken on any equipment without first ensuring all electrical supplies are isolated.

Please be aware that during operation, even if the JABC unit is electrically isolated at its own supply, there may be terminals within it which are still LIVE. Ensure that the source of the supply is also isolated before attempting any service or maintenance operations.

General information

Before Installation

- On receipt of the product, all items should be visually inspected and any damage or shortage should be advised to the supplier immediately.
- Ensure that the correct voltage supply is available for the unit requirement. Damage to electrical components within the unit will occur if this is not observed.
- Check that the proposed equipment location is suitable and provides adequate support for the weight of the unit.
- Check the proposed equipment location for mains services (gas, electric water etc.) before drilling holes for ventilation duct and unit fixings.
- If using external ducting arrangement, ensure ducting route will fall within the limitation of pressure resistance as noted on page 6.

During Installation and subsequent maintenance

- Installation and maintenance are to be performed only by qualified personnel who are familiar with local codes and regulations, and experienced with this type of equipment.
- If lifting equipment is required, ensure that it is suitable for purpose, certificated and that the operatives are qualified to use it.
- Safe working methods are identified and operatives have suitable Personal Protective Equipment (PPE).
- Ensure the working area is clear of obstructions.
- The units contain moving parts and electrical power hazards, which may cause severe injury or death. Disconnect and shut off power before installation or service of the equipment.
- Units must be earthed.
- The electrical covers and fan guards must remain fitted at all times.
- Use of the units outside of the design conditions and the application for which the units were intended may be unsafe and be detrimental to the units, regardless of short or long term operation.
- The units are not designed to withstand loads or stresses from other equipment or personnel. Such extraneous loads or stress may cause failure or injury.

8. Air Flow Calculations

For effective operation, the cellar will require between 6 to 10 air changes per hour. To calculate the fan speed setting needed to achieve the required air change:

- Calculate room volume in m³ (L x W x H)
- Multiply the resulting room volume by a value between 6 and 10 (air changes/hour) to achieve a required figure in m³/h.
- Check the figure against the airflow values (m³/h) for the fan given in Section 4 on page 4 and select the fan speed which best matches this.

The JABC unit comes with a rear entry air inlet connection for direct attachment to an external facing wall (through-wall installation). If an external facing wall is unavailable, the JABC unit can be mounted in a suitable location, with the air inlet connection changed to bottom entry. This is done by exchanging the rear inlet spigot with the bottom entry sealing plate for ducting purpose. Please see page 7 for instructions on how to change the inlet spigot position.

When connecting ducting to the JABC unit, it is recommended that any increase in pressure resistance should be limited as follows:

Fan Speed	Maximum Pressure Resistance (Pascals)
4	90
3	118
2	114
1	60

For 150mm nominal diameter lightweight ducting, the following standard industry values can be used to calculate the pressure resistance for the proposed ducting run:

150mm Circular Duct	Pressure Resistance (Pascals)
1 metre straight length	7
1no. 90 degree bend	15
1no. 45 degree bend	7.5

Example calculation:

Room volume is 6m x 5m x 2.4m (72m³). Multiply this figure by 8 (air changes/hour). This gives a required figure of 576m³/h. Either fan speed 3 or 4 will give the required airflow to achieve 8 air changes per hour.

Installation requires: 6m of straight ducting, 2no. 90 degree bends and 2no. 45 degree bends

Calculation: (6 x 7 Pascals) + (2 x 15 Pascals) + (2 x 7.5 Pascals) = 87 Pascals

Assessment: 87 Pascals resistance is within the limits of the fan at either fan speed 3 or fan speed 4.

Please Note:

Fan speed 1 should only be used for through-wall applications with small room sizes. For extended ducting application, we do not recommend using the unit with fan speed 1. Regardless of room size, please select either fan speed 2, 3 or 4 only.

9. Installation

Important Notes:

1. Ensure that the outside wall is clear from any obstructions
2. Ensure that the selected wall is strong enough to support the unit.
3. Ensure that no other exhausts will blow directly into the air inlet duct.
4. Ensure that all hidden cabling/pipework are checked for before any drilling commences.
5. Ensure that fixings are suitable for the application.
6. Do not position the unit directly opposite the airflow from the main cellar cooler.

- Changing Air Spigot Position

Before installation of the unit, follow these steps to change the position of the air spigot.

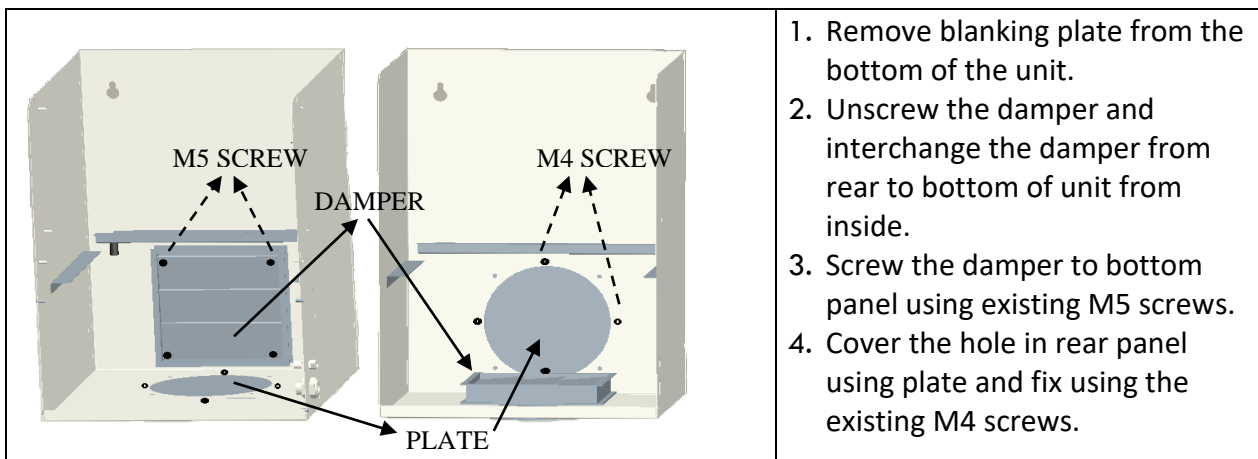

Front view inside cellar room



Side view showing air inlet hole through wall

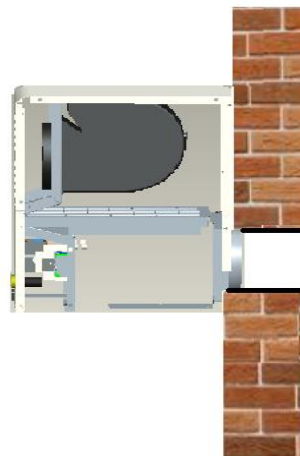

9. Installation

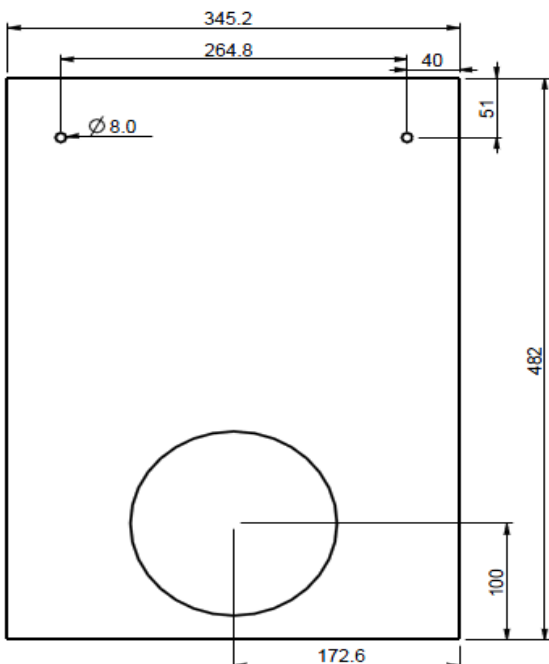
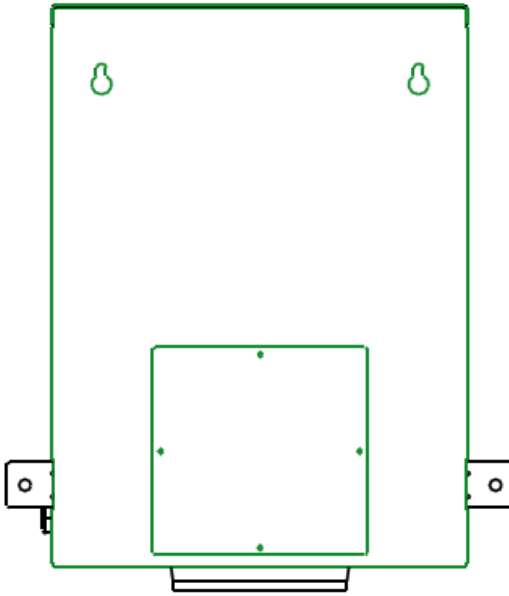
<p>Wall drillings for direct ducting of unit.</p> 	<ol style="list-style-type: none"> 1. Drill the wall fixing points and the hole for the air inlet duct, following the dimensions as shown on the left or follow template supplied. 2. Recommended drill dimension is 157mm diameter for the air inlet duct. 3. Attach required length of 150mm \varnothing ducting to air spigot and seal joint with duct tape or silicon. 4. Pass ambient air probe down inside of ducting. Coil and cable tie excess cable neatly. 5. Remove the top cover of unit for access to fixing holes, and fix to wall. 6. Fix the 2 brackets, one each side of unit using M5 screws and fix to wall. 7. Seal ducting to hole and fix external air grille to ducting. 8. Position ambient air sensor.
<p>Alternative mounting arrangement for ambient cooler</p> 	<p>Spigot can be placed at bottom of unit to enable external ducting to be used. This is the alternative arrangement of the unit where the rear hole is blanked by plate.</p> <p>Note :</p> <ol style="list-style-type: none"> 1. The hole through wall can be drilled in another location. 2. Ducting is not provided.

- Room Air Balance

As the unit can provide up to approximately 700m³/h of airflow into the cellar, this will need to be balanced by allowing air outlet from the room. This can be done by fitting an air grille in the cellar door (provided in the optional installation kit) or by other means.

9. Installation

Electrical Connection & Probe Positioning

Important Note:

The mains electrical supply to the JABC-1 unit must be via a suitably rated isolator and circuit breaker or fuse. There is no isolator fitted to the unit. It requires a 230 volt / 1 phase / 50Hz supply which must include a Neutral and Earth. It is not suitable for any other supply voltages (other than a deviation of +/- 10% of the above values) and is not suitable for 60 Hz supplies.

Important Notes:

1. Ensure that all power supplies have been isolated before starting any electrical work.
 2. Only a qualified electrician should carry out any electrical work.
 3. **Ensure that indoor cellar unit is fully isolated before carrying out this section.**
 4. Make sure that the supply to the JABC-1 unit and the control circuit from the main cellar cooler are using the same electrical phase, otherwise there is potential for 400V at the JABC-1 unit.
 5. Where the main cellar evaporator has only one fan, this should be wired to run continuously (whether the JABC-1 unit is running or not) to maintain proper air circulation within the cellar. For evaporators fitted with multiple fans, it is possible to leave one fan running and switch additional fans off for energy saving when not required (cellar at desired temperature) through relay K2R on the JABC-1 unit. This may require a wiring change to the fans on the evaporator.
 6. **Maximum allowable inductive load for relay K2R is 1.5 Amps. An additional relay will be required for any evaporator fans with amperage greater than 1.5 A.**
-
1. Cable glands are provided for the mains supply cable and the cellar temperature probe cable on the right hand side of the unit. Use the M20 gland for the mains supply cable and the M12 gland for the cellar temperature probe.
 2. **The cellar temperature probe** is coiled up in the control box. Remove the front lower panel on the unit to gain access to the control box.
 3. **The ambient temperature probe** is coiled and stored behind the air damper on the rear of the unit.
 4. Connect the mains supply cable (provided) to the unit as per the diagram on page 12. **Do not switch on the supply yet.**
 5. Isolate the main cellar cooler supply and break the control circuit as per the diagram on page 12. Using a 2 core cable, connect the control circuit from the main cellar cooler to terminal A on the JABC unit and return via terminal B to feed either the main cellar cooler contactor coil or the solenoid valve.
 6. Position the JABC cellar temperature probe unit in a suitable position within the cellar (ideally next to the temperature sensor for the main cellar cooler). The probe cable length is 3m but this can be extended if required.
 7. Position the JABC ambient temperature probe. This can be run down the inside of the air inlet ducting and secured within the external air inlet grille. Ensure sensor is protected from direct sunlight which may affect the temperature reading and the operation of the unit.

10. Commissioning

Important Note:

1. Ensure that all covers are fitted on the unit.
2. Ensure that all electrical connections have been made as per the wiring diagram on page 12.
3. The controllers are fully preset and the settings should not be altered.

1. Switch on power supply to both main cellar unit and JABC-1.
2. The JABC-1 unit should now display outside ambient temperature on the Ambient controller (top) and the cellar temperature on the Cellar controller located below.
3. The cellar temperature set point of the JABC-1 unit is preset to 10°C. **This must not be altered.**
4. The temperature set point of the main cooling should be set at 10°C to match the JABC controller or it can be set 1°C lower than JABC-1 setting if required. The set point of the main cellar cooler should not be set above 10°C.
5. Allow the system to run and ensure that the unit is functioning correctly.

There are 2 external status lights on the front of the JABC-1 unit giving a clear visual display of current operating condition of unit.

Pilot Light Colour	Operating Condition
Yellow	JABC Fan Motor operating
Green	Main cellar cooling function is called for

* Illumination of the Green light for main cellar cooling does not mean that the system is running, just that the main cellar cooling function has been called for.

Controller Alarm Display Information

Ambient Controller

Error Code	Cause
P1	Room probe failure
P2	Evaporator probe failure
HA	Maximum temperature alarm
LA	Minimum temperature alarm

Cellar Controller

Error Code	Cause
PFo	Probe broken or missing
PFc	Probe short circuited
HA	Maximum temperature alarm
LA	Minimum temperature alarm

11. Dimensional Drawing

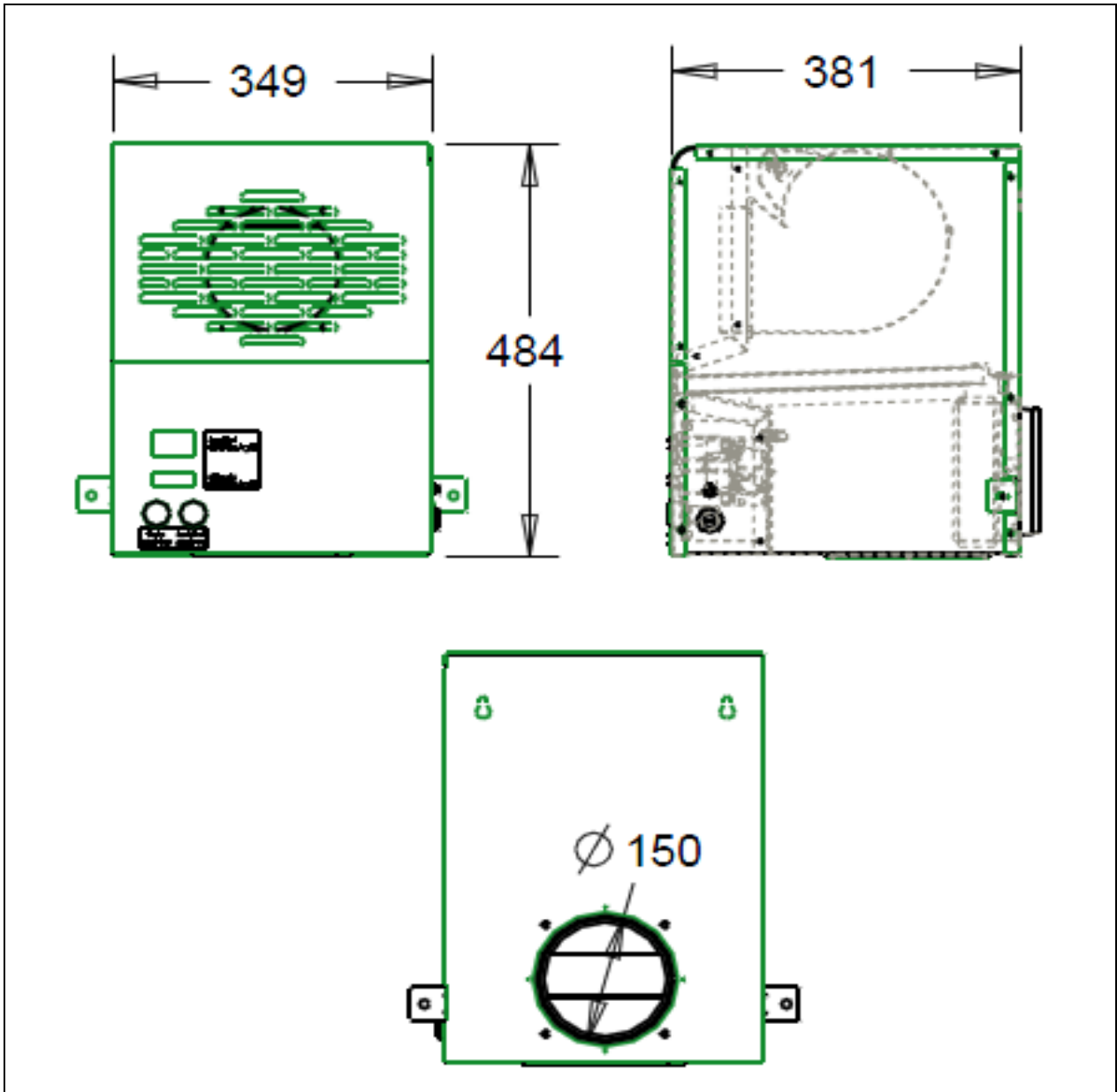

12. Wiring Diagram

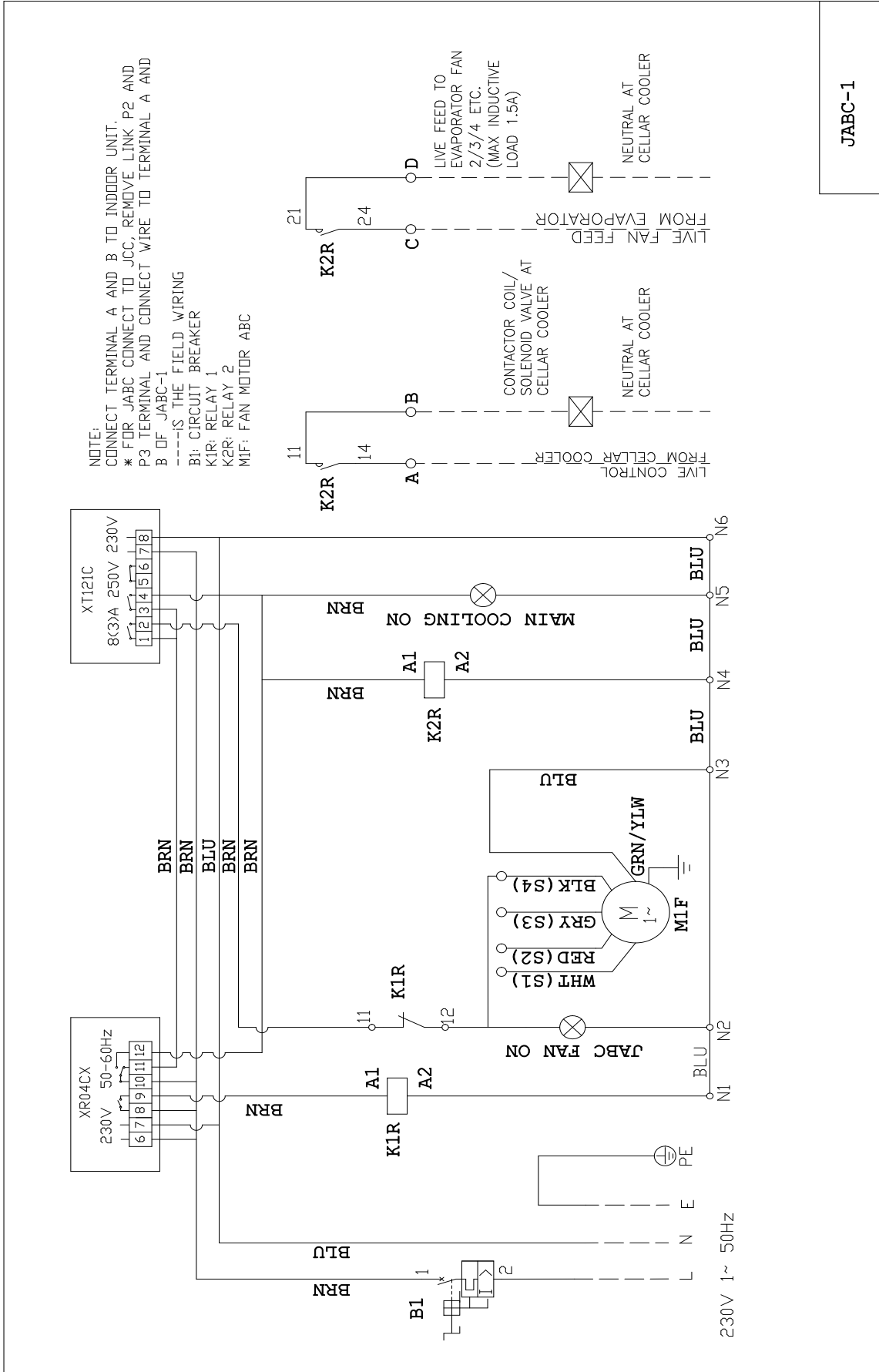

13. Service & Maintenance

Important Note:



Warning! – Disconnect the mains electrical supply before servicing or opening the units.

The units are designed to give long life operation with minimum maintenance. However, they should be routinely checked and the following service schedule is recommended under normal circumstances:

The front panels and control panel need to be removed to ensure all parts / components mentioned below are accessible:

1. Fan Motor– Inspect at regular intervals
 - Check for abnormal noise and vibration.
2. Power Supply – Inspect at regular intervals
 - Check the running current and voltage for the unit.
 - Check the electrical wiring and retighten connections as necessary.
3. Filter – Clean and inspect at regular intervals
 - Check and clean the filter at 3 months intervals to remove dirt and debris on filter media.
 - Check external air inlet grille for obstructions.
4. Controls
 - Check accuracy of temperature readings.



Remove this cover to access filter



Slide the filter out

Unit decommissioning and disposal

- At the end of the unit's useful life, a suitably qualified person should decommission it. The unit components must be disposed of or recycled as appropriate in the correct manner.

NOTICE

Disposal requirement

Your refrigeration product is marked with this symbol. This means that electrical and electronic products shall not be mixed with unsorted household waste. Do not try to dismantle the system yourself: the dismantling of the refrigeration system, treatment of the refrigerant, of oil and of other parts must be done by a qualified installer in accordance with relevant local and national legislation. Refrigeration equipment must be treated at a specialized treatment facility for re-use, recycling and recovery. By ensuring this product is disposed of correctly, you will help to prevent potential negative consequences for the environment and human health. Please contact the installer or local authority for more information.



Batteries must be removed from the controller and disposed of separately in accordance with relevant local and national legislation.

13. Service & Maintenance

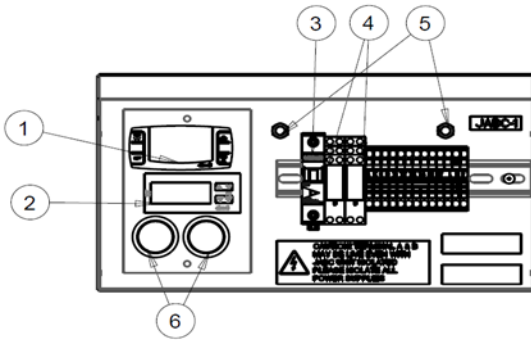

Item	Description
1	CONTROLLER (AMBIENT)
2	CONTROLLER (CELLAR)
3	MCB
4	RELAYS
5	CABLE GLANDS
6	PILOT LAMPS

14. Troubleshooting

In the event of a JABC unit malfunction, please check the following items. Consult a qualified person before any corrective actions are taken.

Failure	Possible Causes
Unit does not operate	<ul style="list-style-type: none"> • Check power supply to unit. • MCB / safety device tripped.
Air Flow becomes slower	<ul style="list-style-type: none"> • Check whether air filter is clogged with dust. • Check outside air inlet grille is not blocked. • Check whether fan speed has been altered.
Error message on either of temperature controllers	<ul style="list-style-type: none"> • Controller/temperature probe failed. Call Service Engineer.

15. Certification

DOC/013-15(0)



DAIKIN REFRIGERATION MALAYSIA SDN. BHD.
LOT 10, JALAN PERUSAHAAN 8, KAWASAN PERUSAHAAN PEKAN BANTING,
42700 BANTING, SELANGOR DARUL EHSAN, MALAYSIA.

Declaration of Conformity

Konformitätsbescheinigung
Déclaration de Conformité
Conformiteitsverklaring
Declaración de Conformidad
Dichiarazione di Conformità
Overensstemmelseserklæring
Declaração de Conformidade
Δήλωση Συμμόρφωσης
Deklaracja zgodności

declare under our sole responsibility that the products
bescheinigen auf unsere eigene Verantwortung, daß die Produkten
déclarons sous notre seule responsabilité que les produits
verklaren onder onze uitsluitende verantwoordelijkheid de producten
declaramos sobre nuestra sola responsabilidad que los productos
dichiariamo sotto nostra sola responsabilità che i prodotti
erklærer som eiansvarlige, at produktet
declaramos sob a nossa responsabilidade exclusiva que os produtos
δηλώνει υπό την αποκλειστική της ευθύνη ότι τα προϊόντα
oświadcza z pełną odpowiedzialnością, że produkty

Ambient Beverage Cooler



Model Designations: JABC-1

Baumuster-Bezeichnungen:

Désignations Modèles:

Aanduidingen Model:

Designaciones Modelo:

Indicazioni de Modello:

modelbetegnelsen:

Designações do modelo:

Όνομασίες μοντέλων:

Oznaczenia modelu:

which this declaration relates is in conformity with the requirements of the following directives
auf diese Bescheinigung sich beziehen, sind den Vorschriften der Normen entsprechend
auxquels se réfère cette déclaration, sont conformes aux prescriptions des directives
waarop deze verklaring betrekking heeft, in overeenstemming is/zijn met de eisen van de volgende richtlijnen
a los cuales se refieren esta declaración, son conformes a las prescripciones de las directivas
alla quale si riferisce questa dichiarazione, sono conformi alle prescrizioni delle direttive
som denne erklæring vedrører, er i overensstemmelse med kravene fremsat i følgende direktiver
que esta declaração está conforme os requerimentos das seguintes direttrizes
τα οποία αφορά αυτή η δήλωση συμμορφώνονται με τις απαιτήσεις των παρακάτω οδηγιών
których dotyczy ta deklaracja są zgodne z wymaganiami następujących Dyrektyw

Low Voltage Directive

2006/95/EC

The conformity was checked for LVD in accordance with the following harmonised EN standard:
Die Konformität wurde auf LVD in Übereinstimmung mit dem folgenden harmonisierten en-Standard überprüft:
La conformité a été vérifiée pour LVD conformément aux normes EN-harmonisées:
De conformiteit is gecontroleerd voor LVD in overeenstemming met de volgende geharmoniseerde EN-norm:
La conformidad se repasa para LVD de acuerdo con el siguiente EN-armonizadas:
La conformità è stata controllata per LVD in conformità con il seguente standard armonizzato dell' EN:
Overensstemmelsen blev tjekket for LVD i henhold til den harmoniserede EN-standard:
A conformidade foi verificada por LVD de acordo com a norma harmonizada EN seguinte:
Η συμμόρφωση ελέγχθηκε ως προς τις οδηγίες LVD σύμφωνα με το παρακάτω εναρμονισμένο πρότυπο EN:
Zgodność produktów została sprawdzona przez LVD zgodnie z poniższą zharmonizowaną normą PL:

MD IEC/ EN 60335-1
IEC/ EN 60335-2-65

Safety of Household and Similar Electrical Appliances: Part I
Safety of Household and Similar Electrical Appliances: Part II

General Manager

Teh Yeow Chong

Issue Date: 16 December 2015

J & E Hall Limited
Hansard Gate
West Meadows
Derby, DE21 6JN
England

Tel: + 44 (0) 1332 253400
Fax: + 44 (0) 1332 371061
Email: helpline@jehall.co.uk
www.jehall.com



Issue: 01.07.2020