V3 FUSION & FUSION SCROLL Commercial Condensing Units

Medium & Low Temperature Applications

ISSUE: 01.06.2023



IMPORTANT!

READ BEFORE PROCEEDING!

GENERAL SAFETY GUIDELINES



This guideline is intended for users to ensure safe installation, operation, and maintenance of J & E Hall Fusion & Fusion scroll condensing units. This guideline is not intended to replace the system expertise available from the system manufacturers.

This equipment is a relatively complicated apparatus. During installation, operation, maintenance or service, individuals may be exposed to certain components or conditions including, but not limited to refrigerants, materials under pressure, rotating components, and both high and low voltage. Each of these items has the potential, if misused or handled improperly, to cause bodily injury or death. It is the obligation and responsibility of operating/service personnel to identify and recognize these inherent hazards, protect themselves, and proceed safely in completing their tasks. Failure to comply with any of these requirements could result in serious damage to the equipment and the property in which it is situated, as well as severe personal injury or death to themselves and people at the site.

This document is intended for use by owner-authorized operating/service personnel. It is expected that these individuals possess independent training that will enable them to perform their assigned tasks properly and safely. It is essential that, prior to performing any task on this equipment, this individual shall have read and understood this document and any referenced materials. This individual shall also be familiar with and comply with all applicable governmental standards and regulations pertaining to the task in question.

SAFETY SYMBOLS

The following symbols are used in this document to alert the reader to specific situations:

 WARNING	Warning! Risk of serious injury or death to person!
 CAUTION	Caution! Danger which can lead to serious damages!
 NOTICE	Notice! Risk of damage to equipment!

NOTICE

Disposal requirement:



Your refrigeration product is marked with this symbol. This means that electrical and electronic products shall not be mixed with unsorted household waste. Do not try to dismantle the system yourself: the dismantling of the refrigeration system, treatment of the refrigerant, of oil and of other parts must be done by a qualified installer in accordance with relevant local and national legislation. Refrigeration equipment must be treated at a specialized treatment facility for re-use, recycling and recovery.

By ensuring this product is disposed of correctly, you will help to prevent potential negative consequences for the environment and human health. Please contact J & E Hall for more information.



Batteries must be removed from the controller if applicable and disposed of separately in accordance with relevant local and national legislation.

Contents

NOMENCLATURE	1	<i>Figure 15: Outline Drawing Series 6</i>	12
PRODUCT FEATURES	1	WIRING DIAGRAMS	13
SPECIFICATIONS	1	<i>Figure 16: JEHR-0050-B1-M-1</i>	13
<i>Table 1: Technical Data</i>	2	<i>Figure 17: JEHR-0067/0100/0113-B1-M-1</i>	13
PERFORMANCE DATA	3	<i>Figure 18: JEHR-0115/0135-B1-L-1</i>	14
APPLICATION GUIDELINES	3	<i>Figure 19: JEHR-0140/0170-B2-M-1</i>	14
<i>Table 2: Operating Limit</i>	3	<i>Figure 20: JEHR-0140/0170-B2-M-3</i>	15
HEALTH AND SAFETY	3	<i>Figure 21: JEHR-0180/0210-B2-L-1</i>	15
GENERAL INFORMATION.....	3	<i>Figure 22: JEHR-0180/0210-B2-L-3</i>	16
INSTALLATION	4	<i>Figure 23: JEHS-0200/0250/0300/0350-B2-M-1</i>	16
UNIT LOCATION	4	<i>Figure 24: JEHS-0200/0250/0300/0350-B2-M-3,</i> <i>JEHS-0300-B2-L-3</i>	17
<i>Figure 1: Positioning of condensing unit</i>	4	<i>Figure 25: JEHS-0350/0400-B3-M-1</i>	17
<i>Figure 2: Air circulation for condenser</i>	4	<i>Figure 26: JEHS-0350/0400/0500/0600/0680-B3-M-</i> <i>3, JEHS-0400/0500/0600-B3-L-3</i>	18
INSTALLATION CLEARANCES.....	4	<i>Figure 27: JEHS-0800/1000-B4-M-3</i>	18
<i>Figure 3: Installation Clearance</i>	4	<i>Figure 28: JEHS-1300-B4-M-3, JEHS-1500-B6-M-3</i> ..	19
FIELD PIPING.....	4	<i>Figure 29: JEHS-0750-B4-L-3</i>	19
<i>Figure 4: Piping layout for outdoor above indoor</i>	5	<i>Figure 30: JEHS-0951-B4-L-3 EVI</i>	20
<i>Figure 5: Piping layout for outdoor below indoor</i>	5	<i>Figure 31: JEHS-1150-B4-L-3 EVI</i>	20
PRESSURE TESTING	6	<i>Figure 32: JEHS-1400-B4-L-3 EVI</i>	21
<i>Table 3: Maximum working pressure</i>	6	SERVICE & MAINTENANCE	22
EVACUATION AND CHARGING.....	6	<i>Table 13: Torque Tightening</i>	23
ELECTRICAL.....	6	F-GAS REQUIREMENT	24
REVERSE ROTATION PROTECTION AND VOLTAGE UNBALANCE	7	<i>Table 14: Tonnes CO₂ Equivalent</i>	24
COMMISSIONING	7	<i>Table 15: Leak Inspection Frequency</i>	24
SCROLL COMPRESSOR OPERATION	7	<i>Table 16: Trouble Shooting</i>	24
DUAL PRESSURE SWITCH.....	7	<i>Figure 33: Declaration of conformity</i>	27
<i>Figure 6: Saginomiya DNS-D306</i>	7	<i>Figure 34: Declaration of incorporation</i>	29
<i>Figure 7: Adjustment on Danfoss KP17WB</i>	8	<i>Figure 35: EU Declaration of conformity</i>	30
<i>Figure 8: KP17WB: high pressure reset option</i>	8	<i>Figure 36: EU Declaration of incorporation</i>	32
<i>Table 4: Dual Pressure Switch Manufacturer Setting</i>	8		
PRESSURE SWITCH SETTINGS	8		
<i>Table 5: Compressor operating pressures in barg</i>	8		
CRANKCASE HEATERS	9		
FAN SPEED CONTROLLER XGE-4C	9		
<i>Figure 9: Full voltage adjustment on XGE-4C</i>	9		
<i>Table 6: FSC settings to obtain ecodesign data</i>	9		
FAN CONTROL SWITCH SYS-C130	9		
<i>Table 7: Fan control switch factory setting</i>	9		
DISCHARGE THERMOSTAT	9		
VOLTAGE MONITORING DEVICE MG73BF	10		
<i>Table 8: LED indication on front plate of MG73BF</i> ..	10		
VAPOR INJECTION CONTROLLER EXD-HP1.....	10		
<i>Table 9: Digital input status of EXD-HP1</i>	10		
<i>Figure 10: Display/ keypad unit (LEDs and button</i> <i>functions)</i>	11		
<i>Table 10: Display parameters</i>	11		
<i>Table 11: Parameter list for manual mode operation</i>	11		
.....	11		
<i>Table 12: EXD-HP1 error/ alarm handling</i>	11		
OUTLINE DRAWING	12		
<i>Figure 11: Outline Drawing Series 1</i>	12		
<i>Figure 12: Outline Drawing Series 2</i>	12		
<i>Figure 13: Outline Drawing Series 3</i>	12		
<i>Figure 14: Outline Drawing Series 4</i>	12		

Nomenclature

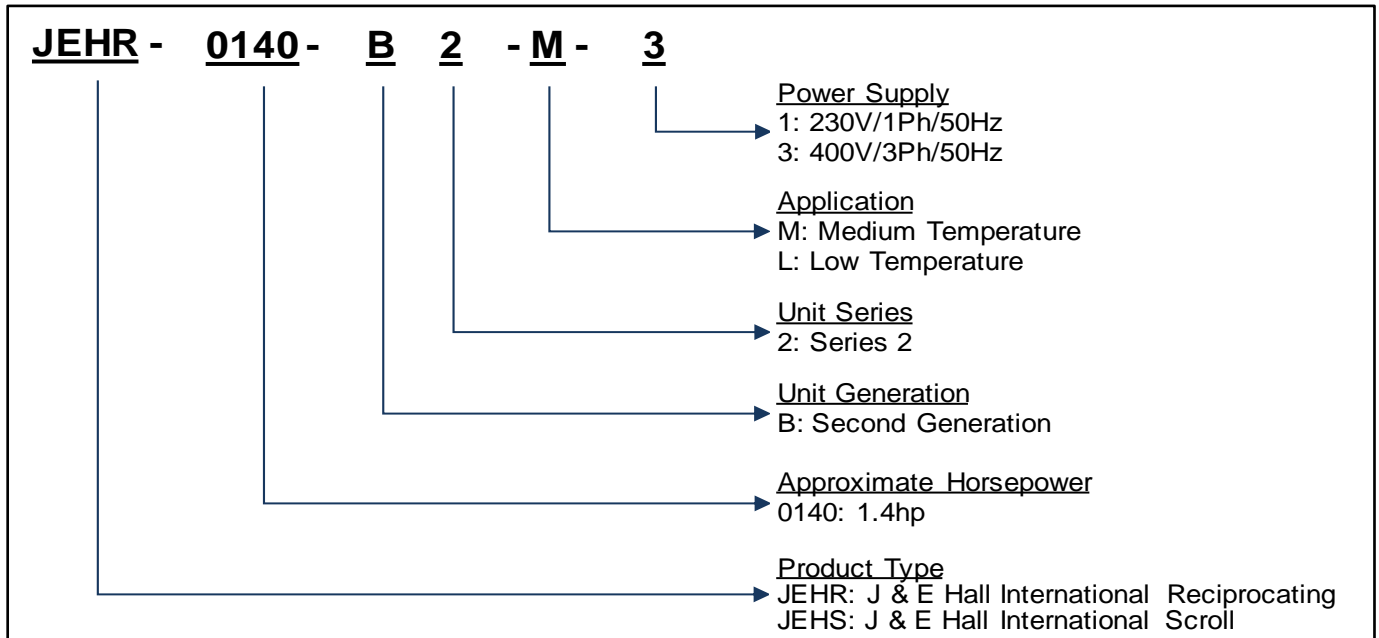

Product Features

J & E Hall V3 Fusion and Fusion Scroll condensing unit adopt fix speed compressor in a flexible plug and play package, for medium and low temperature refrigeration application.

Standard features for all medium and low temperature model:

- Tecumseh reciprocating compressors
- Copeland scroll compressors
- Microchannel condenser coil in -B1 and -B2 units
- Liquid receiver with fusible plug
- Fitted liquid line drier & sight glass
- Dual LP/HP Pressure control
- Flexible pressure hoses
- External service valves
- IP rated enclosure
- Combined mains isolator with short circuit / overload protection
- Fuse protection to fan and control circuit
- Fan speed control (except -B1-M-1 units)
- Crankcase heater on compressor (except -B1-M-1 units)
- Alarm output available from high pressure switch
- Acoustic insulation to compressor compartment

Specifications

Indicator:

- **Oil Type A:** Uniqema Emkarate RL32CF
- **Oil Type B:** Polyolester Oil - (Copeland Ultra 22 CC, Copeland Ultra 32 CC, Copeland Ultra 32-3MAF, Mobil EAL Arctic 22CC, Uniqema Emkarate RL32CF)
- COP/SEPR according to Ecodesign conditions.
- n/c: not compatible with this refrigerant
- n/a: compatible with this refrigerant but no data available at Ecodesign condition or does not meet Ecodesign requirement
- ^a NC: Nominal Current rated at condition (-10°C Te / +32°C Ta) for MT and (-35°C Te / +32°C Ta) for LT with R448A refrigerant.
- ^b MCC: Maximum Continuous Current
- ^c LRC: Locked Rotor Current
- ^d SPL @10m: Sound Pressure Level measured 10m from unit, in an anechoic room rated at (-10°C Te / +32°C Ta) for MT and (-25°C Te / +32°C Ta) for LT. Alternative conditions may produce different results
- FLC: Full load current of fan

Table 1: Technical Data

App.	Unit Model	Series	COP / (SEPR)					Compressor			Oil Sep. Charge	Oil Type	Electrical Data					Coil Volume	Liquid Receiver Volume	Airflow	Connections		Dimensions		Unit Dry Weight	SPL @ 10m ^d				
			R134a	R407A	R407F	R448A	R449A	R452A	Type	Sw ept Volume			Oil Charge	Compressor			Fan				Liquid	Gas	Unit (W x D x H)	Mounting (W x D)						
											(m³/h)			(Litres)	(Litres)	NC ^a	MCC ^b	LRC ^c	No.	Total FLC										
			(A)	(A)	(A)	(A)	(Litres)	(Litres)	(Litres)	(inch)	(inch)		(mm)	(mm)	(kgs)	dB(A)														
Medium Temperature	JEHR-0050-B1-M-1	1	n/c	1.59	1.77	1.66	1.66	1.67	AE4460Z-FZ1C	1.80	0.28	-	A	3.4	5.9	19.4	1	0.2	0.44	2.4	1250	1/4	3/8	876 x 430 x 606	545 x 400	49	28			
	JEHR-0067-B1-M-1		n/c	1.62	1.76	1.64	1.64	1.67	CAJ9480Z	2.64	0.48	-		3.1	6.7	24.1	1	0.2	0.44	2.4	1250	3/8	1/2			56	28			
	JEHR-0100-B1-M-1		n/c	1.66	1.77	1.64	1.64	1.68	CAJ9510Z	3.18	0.48	-		3.9	8.4	29.5	1	0.2	0.44	2.4	1250	3/8	1/2			57	28			
	JEHR-0113-B1-M-1		n/c	1.78	1.85	1.71	1.71	1.73	CAJ9513Z	4.21	0.48	-		4.9	11.3	33.5	1	0.2	0.44	2.4	1250	3/8	1/2			58	28			
	JEHR-0140-B2-M-1	2	n/c	1.74	1.93	2.09	2.09	1.92	CAJ4517Z	4.52	0.48	-		5.3	12.7	38.5	1	0.6	0.51	4.5	2700	3/8	1/2	1101 x 444 x 662	703 x 408	67	32			
	JEHR-0140-B2-M-3		n/c	1.66	1.85	2	2	1.83	TAJ4517Z	4.52	0.48	-		2.3	4.0	18.0	1	0.6	0.51	4.5	2700	3/8	1/2			67	32			
	JEHR-0170-B2-M-1		n/c	n/c	n/c	1.73	1.73	1.65	CAJ4519Z	6.00	0.48	-		6.4	15.2	45.0	1	0.6	0.51	4.5	2700	3/8	5/8			68	33			
	JEHR-0170-B2-M-3		n/c	n/c	n/c	1.76	1.76	1.73	TAJ4519Z	6.00	0.48	-		3.1	4.8	22.0	1	0.6	0.51	4.5	2700	3/8	5/8			68	33			
	JEHS-0200-B2-M-1	2	1.92	2.18	1.92	2.02	2.02	n/c	ZB15KQE-PFJ	5.90	1.30	-		7.3	18.5	58.0	1	0.6	0.51	4.5	2700	3/8	3/4			70	33			
	JEHS-0200-B2-M-3		2.19	2.12	1.88	2.02	2.02	n/c	ZB15KQE-TFD	5.90	1.30	-		2.9	7.0	26.0	1	0.6	0.51	4.5	2700	3/8	3/4			70	33			
	JEHS-0250-B2-M-1		n/a	2.06	1.83	1.93	1.93	n/c	ZB19KQE-PFJ	6.80	1.30	-		9.3	20.5	61.0	1	0.6	0.51	4.5	2700	3/8	3/4			72	34			
	JEHS-0250-B2-M-3		n/a	1.99	1.83	1.93	1.93	n/c	ZB19KQE-TFD	6.80	1.30	-		4.2	7.0	32.0	1	0.6	0.51	4.5	2700	3/8	3/4			72	34			
	JEHS-0300-B2-M-1		n/a	n/a	1.74	1.85	1.85	n/c	ZB21KQE-PFJ	8.60	1.45	-		12.2	21.5	82.0	1	0.6	0.51	4.5	2700	3/8	3/4			74	36			
	JEHS-0300-B2-M-3		n/a	1.92	1.69	1.85	1.85	n/c	ZB21KQE-TFD	8.60	1.45	-		4.4	10.3	40.0	1	0.6	0.51	4.5	2700	3/8	3/4			74	36			
	JEHS-0350-B2-M-1		1.86	n/a	n/a	(2.72)	(2.72)	n/c	ZB26KQE-PFJ	9.90	1.50	-		14.8	25.0	97.0	1	0.6	0.51	4.5	2700	3/8	3/4			74	39			
	JEHS-0350-B2-M-3		2.08	n/a	n/a	(2.72)	(2.72)	n/c	ZB26KQE-TFD	9.90	1.50	-		5.8	9.0	46.0	1	0.6	0.51	4.5	2700	3/8	3/4			74	39			
	JEHS-0350-B3-M-1	3	2.13	(3.43)	(3.16)	(3.02)	(3.02)	n/c	ZB26KQE-PFJ	9.90	1.50	-		13.9	25.0	97.0	1	0.9	4.42	7.6	4250	1/2	3/4	1353 x 575 x 872	945 x 500	112	37			
	JEHS-0350-B3-M-3		2.36	(3.48)	(3.22)	(3.02)	(3.02)	n/c	ZB26KQE-TFD	9.90	1.50	-		5.9	9.0	46.0	1	0.9	4.42	7.6	4250	1/2	3/4			112	37			
JEHS-0400-B3-M-1	n/a		(3.61)	(3.54)	(3.13)	(3.13)	n/c	ZB29KQE-PFJ	11.40	1.36	-	16.1	28.0	114.0	1	0.9	4.42	7.6	4250	1/2	7/8	119	37							
JEHS-0400-B3-M-3	2.36		(3.79)	(3.49)	(3.13)	(3.13)	n/c	ZB29KQE-TFD	11.40	1.36	-	7.3	11.0	50.0	1	0.9	4.42	7.6	4250	1/2	7/8	119	37							
JEHS-0500-B3-M-3	n/a		(3.21)	(3.07)	(2.97)	(2.97)	n/c	ZB38KQE-TFD	14.40	2.07	-	8.2	13.5	65.5	1	0.9	4.42	7.6	4250	1/2	7/8	123	38							
JEHS-0600-B3-M-3	n/a		(3.19)	(3.12)	(3.22)	(3.22)	n/c	ZB45KQE-TFD	17.10	1.89	-	8.7	14.2	74.0	1	0.9	6.89	7.6	4100	1/2	1 1/8	125	40							
JEHS-0680-B3-M-3	n/a		(2.96)	n/a	(2.96)	(2.96)	n/c	ZB48KQE-TFD	18.80	1.80	-	11.4	19.1	101.0	1	0.9	6.89	7.6	4100	1/2	1 1/8	126	40							
JEHS-0800-B4-M-3	4	(3.10)	(3.12)	(2.95)	(2.88)	(2.88)	n/c	ZB57KQE-TFD	21.40	1.89	-	9.6	21.3	102.0	2	1.8	8.73	13.6	8500	3/4	1 1/8	1348 x 612 x 1727	940 x 560	204	43					
JEHS-1000-B4-M-3		(3.37)	n/a	n/a	(2.83)	(2.83)	n/c	ZB76KQE-TFD	29.10	3.20	-	14.4	28.0	118.0	2	1.8	8.73	13.6	8500	3/4	1 3/8			226	43					
JEHS-1300-B4-M-3		(3.09)	n/a	n/a	(2.97)	(2.97)	n/c	ZB95K5E-TFD	36.40	3.37	0.6	20.2	34.0	140.0	2	1.8	12.84	13.6	8200	3/4	1 3/8			238	46					
JEHS-1500-B6-M-3	6	(2.96)	n/a	n/a	(2.94)	(2.94)	n/c	ZB114K5E-TFD	43.40	3.37	0.6	24.0	38.0	174.0	2	3.4	19.00	18.0	11340	3/4	1 3/8	1735 x 854 x 1727	1240 x 808	332	48					
Low Temperature	JEHR-0115-B1-L-1	1	n/c	n/c	n/c	n/a	n/a	1.05	CAJ2446Z	4.55	0.48	-	A	2.8	8.2	30.0	1	0.2	0.44	2.4	1250	3/8	1/2	876 x 430 x 606	545 x 400	59	27			
	JEHR-0135-B1-L-1		n/c	n/c	n/c	n/a	n/a	0.98	CAJ2464Z	6.00	0.48	-		4.6	10.0	40.0	1	0.2	0.44	2.4	1250	3/8	1/2			61	27			
	JEHR-0180-B2-L-1	2	n/c	n/c	n/c	0.96	0.96	1.03	FH2480Z-XC3A	9.45	1.14	0.5		6.1	12.0	65.0	1	0.6	0.51	4.5	2700	3/8	5/8	1101 x 444 x 662	703 x 408	81	35			
	JEHR-0180-B2-L-3		n/c	n/c	n/c	1.00	1.00	1.07	FH2480Z-XG1A	9.45	1.14	0.5		2.5	6.4	31.0	1	0.6	0.51	4.5	2700	3/8	5/8			80	35			
	JEHR-0210-B2-L-1		n/c	n/c	n/c	0.99	0.99	0.99	FH2511Z-XC3A	11.83	1.14	0.5		6.7	24.0	71.0	1	0.6	0.51	4.5	2700	3/8	5/8			83	38			
	JEHR-0210-B2-L-3		n/c	n/c	n/c	1.00	1.00	1.05	FH2511Z-XG1A	11.83	1.14	0.5		3.4	8.3	60.0	1	0.6	0.51	4.5	2700	3/8	5/8			81	38			
	JEHS-0300-B2-L-3	3	n/c	n/a	n/a	0.97	0.97	n/c	ZF09KQE-TFD	8.00	1.50	0.5		3.8	6.5	40.0	1	0.6	0.51	4.5	2700	3/8	3/4	1353 x 575 x 872	945 x 500	78	33			
	JEHS-0400-B3-L-3		n/c	(1.67)	(1.65)	(1.67)	(1.67)	n/c	ZF13KQE-TFD	11.80	1.90	0.6		4.9	10.0	51.5	1	0.9	4.42	7.6	4250	1/2	7/8			132	37			
	JEHS-0500-B3-L-3		n/c	(1.67)	(1.64)	n/a	n/a	n/c	ZF15KQE-TFD	14.50	1.90	0.6		6.7	12.0	64.0	1	0.9	4.42	7.6	4250	1/2	7/8			132	39			
	JEHS-0600-B3-L-3		n/c	(1.64)	n/a	(1.64)	(1.64)	n/c	ZF18KQE-TFD	17.10	1.90	0.6		7.6	12.5	74.0	1	0.9	4.42	7.6	4250	1/2	7/8			133	41			
	JEHS-0750-B4-L-3		4	n/c	n/a	n/a	(1.64)	(1.64)	n/c	ZF25K5E-TFD	21.40	1.90		0.6	6.9	16.6	102.0	2	1.2	4.14	13.6	5750	1/2			1 1/8	1348 x 612 x 1727	940 x 560	203	41
	JEHS-0951-B4-L-3 EV1			n/c	(1.65)	(1.74)	(1.68)	(1.68)	n/c	ZF26KQE-TFD	17.10	1.90		0.6	7.3	13.0	74.0	2	1.2	8.73	13.6	5870	1/2			7/8			200	37
JEHS-1150-B4-L-3 EV1	n/c	(1.68)		(1.78)	(1.71)	(1.71)	n/c	ZF36KQE-TFD	21.40	1.90	0.6	8.9	16.6	102.0	2	1.8	8.73	13.6	8500	1/2	1 1/8	211	42							
JEHS-1400-B4-L-3 EV1	n/c	(1.89)		n/a	(1.67)	(1.67)	n/c	ZF34K5E-TFD	29.10	3.37	0.6	13.7	25.0	100.0	2	1.8	12.84	13.6	8200	1/2	1 3/8	235	44							

Performance Data

Scan below QR code to access <https://commercial.jehall.co.uk/> to view performance data, eco design sheet, technical manual.



Application Guidelines



NOTICE

It should ensure that the refrigeration system which adopts this condensing unit, wherever possible to integrate pump down features. This is to avoid liquid compression which could damage the compressor.



CAUTION

malfunction.

Ensure that new compressors are not subjected to liquid abuse. Turn the crankcase heater on 12 hours before starting the compressor to avoid oil dilution and bearing

Table 2: Operating Limit

Operating Limits	Recommendation
Maximum discharge gas temperature	Fusion: 120°C Fusion scroll: 130°C
Low pressure side	Minimum 0.5barg; Maximum 19barg
High pressure side	Maximum 28barg
Evaporator outlet superheat	Above 6K (to avoid liquid flood back)
Suction gas superheat at compressor inlet	Not more than 20K
Voltage supply	1phase: Min: 207V, Max: 253V 3phase: Min: 360V, Max: 440V
Phase asymmetry	+/- 2%
Frequency	50Hz +/- 1%
Outdoor ambient	Min: -20°C, Max: 43°C (except -B1-M-3, where head pressure control is recommended to be integrated for ambient below 10°C to avoid erratic expansion valve operation)
Maximum pipe run	Fusion: 25m Fusion scroll: 50m

Suction line shall be insulated to avoid:

- High superheat during high ambient condition can create high discharge temperature.
- Too low superheat during low ambient condition that can condense refrigerant inside suction line.

Health and Safety



CAUTION

Only qualified personnel, who are familiar with refrigeration systems and components including all controls, should perform the installation and start-up of the system. To

avoid potential injury, use care when working around coil surfaces or sharp edges of metal cabinets. All piping and electrical wiring should be installed in accordance with all applicable standards and local by-laws.

General information

Before Installation

- Ensure the units received are the correct models for the intended application.
- Ensure the refrigerant, voltage and maximum working pressure are all suitable for the proposed application.
- Check there is no damage to the units. Any damage should be reported to the supplier immediately.
- Check that the proposed equipment locations are suitable and provide adequate support for the weight of the units.

Offloading and Lifting

- Whenever a condensing unit is lifted, it should be from the base and, where possible, all packing and protection is kept in position.
- If lifting equipment is required, ensure that it is suitable, certificated, and that the operators are qualified to use it.
- When using a fork-lift or pallet truck to lift the unit, the two support points should be sufficiently apart to give stability when lifting and suitably placed to distribute the load on the forks.
- If slings are used, care should be taken to ensure that the slings do not crush the casework or coil.
- When lifting by crane, use spreader bars to prevent compressing the top of the equipment.
- Do not drop the unit. Should this inadvertently happen, it should be immediately unpacked and inspected for damage.
- Use the appropriate spreader bars/lifting sling with the holes and lugs provided.

During Installation and subsequent maintenance

- Installation and maintenance are to be performed only by qualified personnel who are familiar with local codes and regulations and experienced with this type of equipment.
- Safe working methods are identified, and operators should/must have suitable Personal Protective Equipment (PPE).
- Ensure the working area has adequate ventilation during brazing procedures.
- The units contain moving machinery and electrical power hazards, which may cause severe injury or death. Disconnect and shut off power before installation or service of the equipment.
- Refrigerant release into the atmosphere is illegal. Proper evacuation, recovery, handling, and leak testing procedures must be observed all the time.
- Units must be **grounded to the screw terminal labelled**



- No maintenance work should be attempted prior to disconnecting the electrical supply.
- The electrical covers and fan guards must remain fitted all the time.
- Use of the units outside of the design conditions and the application for which the units were intended may be

unsafe and be detrimental to the units, regardless of short or long-term operation.

- The units are not designed to withstand loads or stress from other equipment or personnel. Such extraneous loads or stress may cause failure/leak/injury.
- The units are not designed to operate with any restrictions such as heavy snowfall around them. Additional measures (such as shielding of the units) shall be implemented as required.
- The installer must fix the unit securely on installation using the M8 bolt holes in the unit feet to prevent instability from accidental contact or from exposure to the elements (e.g.: wind).
- When the compressor operates under stabilized conditions, the oil level must be visible in the sight glass. Foam filling the oil sight glass indicates presence of large concentration of liquid to the compressor.
- No additional oil is required for installation with good oil returns, line runs up to 20m. Additional oil might be required if lines exceeded 20m, with minimum oil level must not lower than ¼ of sight glass (not applicable to compressor without sight glass). Top-up the oil while compressor is idle, via suction schrader connector with a suitable pump.
- Ensure correct rotation of scroll compressor. If there is no compression, shut off the incoming power supply and swap connection of any two of the three incoming phases at the condensing unit's motor rated circuit breaker.

Installation

Unit location

- To achieve maximum cooling capacity, the installation location for the condensing unit should be carefully selected.
- Install the condensing unit in such a way so that hot air ejected by the condensing unit cannot be drawn in again (short circuit of hot discharge air). Allow sufficient space for maintenance around the unit.

Figure 1: Positioning of condensing unit

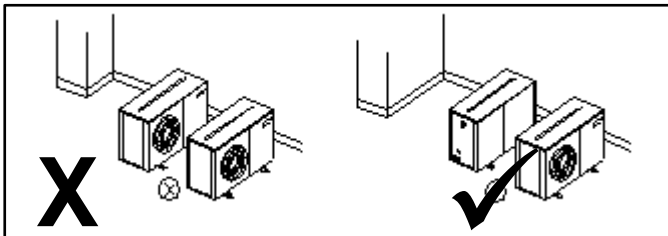

- Ensure that there is no obstruction to air flow into or out of the unit. Remove obstacles which block air intake or discharge.

Figure 2: Air circulation for condenser

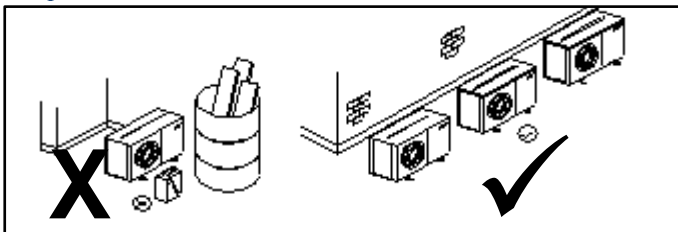

- The location must be well ventilated, so the unit can draw in and distribute plenty of air thus lowering the condensing temperature.
- To optimize the unit running conditions, the condenser coil must be cleaned at regular intervals.
- The unit must be level in all directions.
- It is recommended to install the unit on rubber grommet or vibration dampers.
- Wall mounting on brackets is only suitable for models - B1/-B2/-B3.



NOTICE

Special attention should be given if unit installed near to the sea as this can reduce unit lifespan due to corrosion of metal parts.

Installation clearances

- The installation location should allow sufficient space for air flow and maintenance around the unit.

Figure 3: Installation Clearance

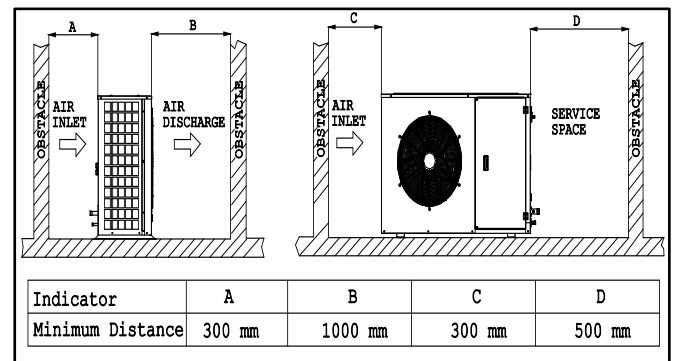

Field Piping



NOTICE

Pipe sizing should only be determined by qualified personnel. Correct line sizing will minimize the pressure drop and maintain sufficient gas velocity for proper oil return. All applicable standards must be observed in the installation of refrigerant piping.

To ensure satisfactory operation and performance, the following points should be noted:

- Pipework routes must be as simple and as short as possible.
- Avoid low points on pipework where oil can accumulate.
- Suction gas velocity must be sufficient to ensure good oil return.
- Use only clean, dehydrated refrigeration grade copper tube with long radius bends.
- Avoid flare type connections and take great care when brazing. Use brazing filler alloys containing phosphorus such as BCuP-7 without flux for joining copper tubes.
- Dissimilar metals such as copper and brass shall be joined using an appropriate flux with high silver content filler material such as BAg-34. Apply flux sparingly to the clean tube only and in a manner to avoid leaving any excess inside of completed joints.

- Run braze without over filling to ensure there is no leakage into the tube.
- To prevent oxidation, blow oxygen free nitrogen through pipework when brazing.
- To prevent condensation on pipe surface, install insulation on all suction lines and on all pipes penetrating walls or passing through hot areas.
- Adequately support all pipe work at a maximum of 2-meter intervals.
- The maximum rise between the two units should be no more than 6 meters, to ensure compressor ability to handle pressure drop.
- In vertical pipework, the use of U-trap and double suction risers is often required. These suction risers must always be fitted with a U-trap at the bottom and a P-trap at the top and never be higher than 4m unless a second U-trap system is fitted.
- Additional oil may be required if piping length exceeds 20m or multiple oil traps are fitted. Check the oil level closely during commissioning and add oil as necessary. Add oil in small amounts. Do not overfill the compressor!
- Suction pipework should slope gently back towards the unit to assist oil return to the compressor. A fall of approximately 2cm per meter of pipework is acceptable.
- Liquid lines should be sized to ensure a full supply of liquid refrigerant to the expansion device. Attention should be paid to the sizing of liquid lines on large risers (maximum rise 6m).
- On systems with a large refrigerant charge and without pump down cycle, or on any system where liquid flood back is likely to occur, a suction accumulator (not supplied) is strongly required. It offers protection against liquid refrigerant flow back during operation and against off-cycle migration by adding internal free volume to the suction side of the system.
- Tests must be conducted to ensure the amount of off-cycle migration to the compressor does not exceed the compressor's charge limit.
- Wherever possible the system should be installed to utilize a pump down configuration.
- Pump down control can be used on all thermostatic expansion valve systems with the addition of a liquid line solenoid valve. By closing a liquid line solenoid valve, the refrigerant can be pumped into the condenser and receiver, and the compressor operation controlled by means of a low-pressure control. The refrigerant can thus be isolated during periods when the compressor is not in operation, and migration of refrigerant to the compressor crankcase is prevented.
- In case of fire incidence, pressure increases due to increasing in temperature at receiver. Hence it is very important to install the Pressure Relief Valve.
- No valves and detachable joints shall be in areas accessible to the public except when they comply with EN 16084.
- Field piping for outdoor unit located below indoor unit: Inverted P-trap is necessary when pump down is not used (Figure 5). To prevent refrigerant from draining into the compressor during off-cycle.



NOTICE

One of the main factors affecting equipment reliability and compressor service life is refrigeration circuit contamination.

During installation, circuit contamination could cause by:

- Brazing & Welding Oxides
- Filings & Particles from de-burring pipework
- Brazing Flux
- Moisture & Air

Figure 4: Piping layout for outdoor above indoor

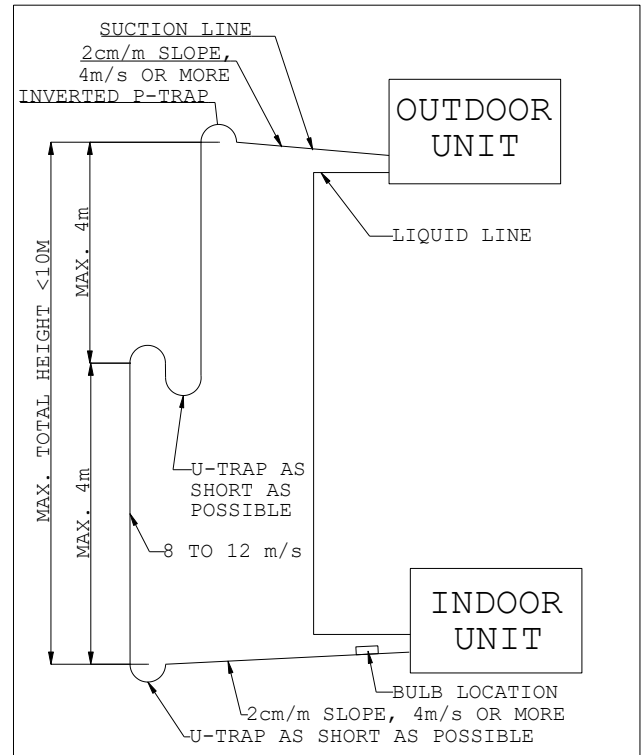
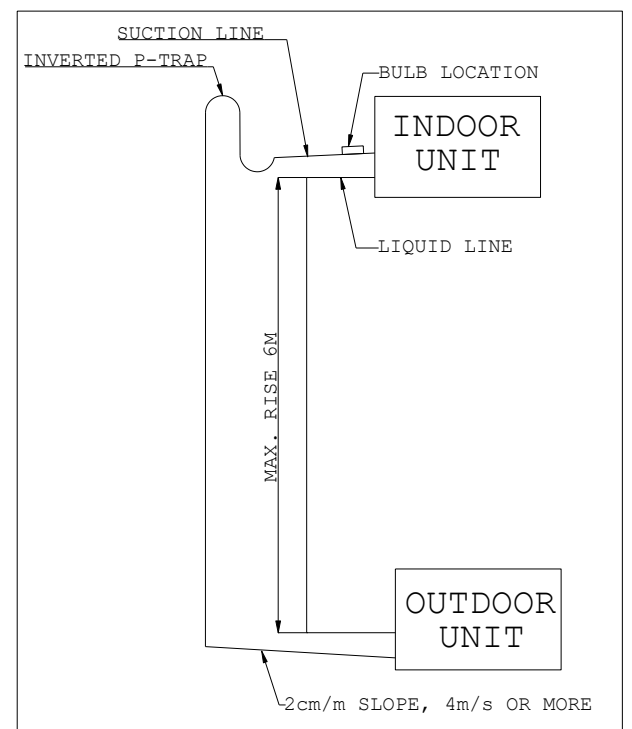

Figure 5: Piping layout for outdoor below indoor



Installation

Pressure Testing



CAUTION

Never use oxygen, dry air, or acetylene for pressure testing of the system as these may form an inflammable mixture.

- The condensing units are pressure tested in the factory prior to dispatch. All units come with a holding charge of oxygen free nitrogen ~2barg. Remove the holding charge indication tag which is tied to service valve before installation.
- Once the pipework installation is complete, it should be pressure tested for leak prior to evacuation.
- A pressure leak test should be carried out using oxygen free nitrogen (OFN). A calibrated nitrogen pressure regulator must always be used. Before starting any pressure testing, ensure the area surrounding the system is safe, inform relevant personnel and fit warning signs indicating high pressure testing. Also, use correct PPE as required.
- Always pressurize the system slowly, preferably in stages up to the maximum required pressure. Never exceed maximum working pressures shown in below table. Failure to obey the limit will cause premature failure on the pressure safety device.

Table 3: Maximum working pressure

High Side, barg (psig)	Low Side, barg (psig)
28 (405)	19 (275)

- Listen for any possible leaks and check all joints with bubble spray. If any leaks are discovered, release pressure slowly from both suction and liquid line of system until empty, repair leak and then repeat pressure testing procedure. Never attempt to repair a leak on a pressurized system.
- A strength test should also be incorporated (to the installed pipework only) according to applicable standards.
- Once testing has been completed satisfactorily, release the pressure from the system gradually and safely to external atmosphere.

Evacuation and Charging



NOTICE

Moisture prevents proper functioning of the compressor and the refrigeration system. Ensure that a good quality vacuum pump is used to pull a minimum vacuum of 250 microns (0.25 torr) measured at refrigeration system, and not at the vacuum pump gauge.

Once pressure testing has been completed, the system needs to be evacuated to remove any moisture from the piping. This can be done as follows:

- Ensure any nitrogen charge is safely released from the system.
- Connect a gauge manifold to the connections on the service valves on the condensing unit.
- Connect a vacuum pump and vacuum gauge to the system.
- Ensure all gauge manifold and service valves in open position.
- Evacuate the system until vacuum is below 250 microns (0.25 torr).

Note: A triple evacuation procedure is recommended for all new systems or where moisture is suspected.

- Once the system is isolated and the vacuum pump is switched off, any rise in pressure indicates that either there may be a leak in the system or moisture is still present. In this case, recheck the system for leaks, repair as necessary, and then repeat the evacuation procedure.
- Once evacuation is completed satisfactorily, the vacuum pump and vacuum gauge can be removed. At this point, the refrigerant charge can be added to the system as required. Refrigerant blend must be charged in liquid form to avoid change of chemical properties.
- Ensure an adequate liquid charge (4~5barg) has been introduced to the high side of the system before starting the compressor.
- The remaining charge is slowly throttled into suction side until the installation has reached a level of stable nominal condition during operation. **Charging liquid into the suction side of the system should ONLY be done with a metering device.** Ensure a minimum operating pressure 0.5 barg is maintained when adding refrigerant to the suction side, otherwise overheating of the compressor may occur. Use calibrated weighing scales to record the amount of refrigerant added to the system.
- Stop the filling once obtain sufficient suction superheat and liquid subcooling, remove the cylinder from circuit.



NOTICE

Refrigerant charge by judging the liquid sight glass does not guarantee as 100% correct way.

Electrical



NOTICE

The mains electrical supply to the condensing unit must be via a suitable motor rated circuit breaker or fuse. A mains isolator is fitted to all condensing units. Therefore, an additional isolator is not required unless site conditions or regulations dictate differently.

J & E Hall Fusion & Fusion Scroll condensing units require power supply single or three phase which include Neutral and an Earth. These systems are not suitable for any other supply voltages (other than specified in Table 2).

- Mains supply cable type and size must be selected to suit the application and the electrical installation should conform to the current local standards.
- Cables to the condensing unit should, wherever possible, be routed through the cable glands supplied on the rear of the units.
- Connect the mains supply to the units as per the wiring diagrams.
- Ensure that the power supply corresponds to the unit and that the power supply is stable.
- Connect power supply according to the present norm and legal requirement. Ensure that the unit is properly connected to the ground.
- 3phase scroll compressor: live wires need correctly terminated at motor rated circuit breaker for the compressor to rotate in correct direction (compression).

- The unit is equipped with a motor circuit breaker with thermal overload and magnetic trip short circuit protection for the unit. It was preset from factory and never set value higher than set current on wiring diagram.

Reverse Rotation Protection and Voltage Unbalance

The condensing unit does not include phase protector except for model JEHS-1400-B4-L-3 EVI; JEHS-1500-B6-M-3 and JEHS-1300-B4-M-3 units. Thus, it is necessary to ensure correct scroll compressor rotation and incoming line voltage variance within +/-2% during commissioning.



CAUTION

3 phase scroll compressors require proper phase sequence to secure right rotation and therefore compression.

- **Do not use a megohmmeter nor apply power to the compressor while the system under vacuum as this may cause internal damage to the compressor.**
- **Never start the compressor under vacuum (do not operate the compressor with the low-pressure cut-out bypassing), as this will cause the rotating part to overheat very quickly causing premature failure.**
- **There must be no more than 10 compressor's start per hour. A higher number reduces the service life of the compressor. There is no minimum off time for the compressors. Adequate minimum run time is required to ensure proper oil return.**

Commissioning

To gain access to the electrical box, turn the motor rated circuit breaker on the side/front of the unit to the OFF position and loosen the screws on the left-hand side of the door. The electrical box is located behind the door. Remove the screws in the electrical box cover to access components.

Pre startup checks

Before starting the condensing unit, the following checks should be carried out as a minimum:

- Check electrical supply is correct and all connections are sound.
- All moving parts are free, and guards are fitted.
- Compressor oil level satisfactory.
- Initial settings for safety switches and fan speed control.
- Overload set correctly on motor rated circuit breaker.
- All valves are in correct operating position.
- Initial refrigerant charge.
- Crankcase heater energized for a minimum of 12 hours before compressor start-up.
- Gauge manifold connected to both low and high sides of system.

Running the unit

- Run the unit and check compressor and condenser fan operation.
- Check system pressures and temperatures, gas charge and running currents of motors to ensure correct operation.

- Check compressor suction superheat. This should be between 10K and 20K for normal operating conditions.
- Final adjustment of safety switch settings and fan speed control.
- Allow the system to run for 3 – 4 hours. Check compressor oil level and top up with the correct oil type as required. Recheck the compressor oil level again after 24 hours operation.
- Carry out final leak test and ensure all panels/covers are fitted and screws tightened.
- Log all information along with the system model and serial numbers for future reference.
- Ensure that the customer / responsible person is provided with basic operating instructions and where electrical isolators are situated in case of emergency.

Scroll Compressor Operation

Scroll compressor motors are designed to run only in one direction. This is not an issue with single phase compressors as they will always run in the correct direction. The correct rotation of a three-phase compressor motor depends on the connection of the three incoming phases to the unit. Correct rotation can be determined by a drop in suction pressure and a rise in discharge pressure when the compressor is energized. Running the compressor for a short period of time in reverse direction will have no negative impact but prolonged running in reverse direction may cause premature failure. **To reverse the rotation of a three-phase scroll compressor, shut off the incoming power supply to the unit, swap connection of any two of the three incoming phases at the unit motor rated circuit breaker, reapply power to the unit and following compressor restart, recheck operating pressures.**

Compressor rotalock connections

All rotalock connections on compressor models are sealed with Loctite 554 thread sealant. The connections should be leak tested at commissioning and during service/maintenance visits. Refer Table 13 for more information including recommended tightening torque.

Dual Pressure Switch

The dual pressure switch fitted to condensing units is auto reset for low pressure side and manual reset for high pressure (fixed differential) are **NOT factory preset for application.**

Figure 6: Saginomiya DNS-D306

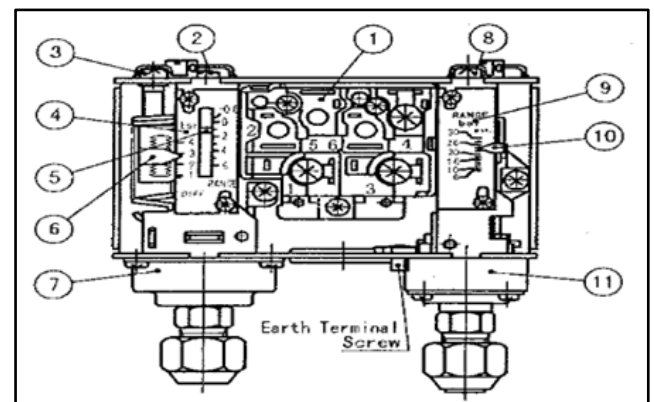

Adjustment on DNS-D306

- **High Pressure Cut Out:** Turning the adjusting screw (8) clockwise to increase the cut-out pressure setting and vice versa. Lock the spindle with locking plate after setting.
- **Low Pressure Cut in:** Turning the range adjusting screw (2) clockwise to decrease the cut-in pressure setting and vice versa.
- **Low Pressure Differential:** Turning the differential adjusting screw (3) clockwise to increase the differential pressure setting and vice versa. Lock the spindle with locking plate after setting.

Figure 7: Adjustment on Danfoss KP17WB

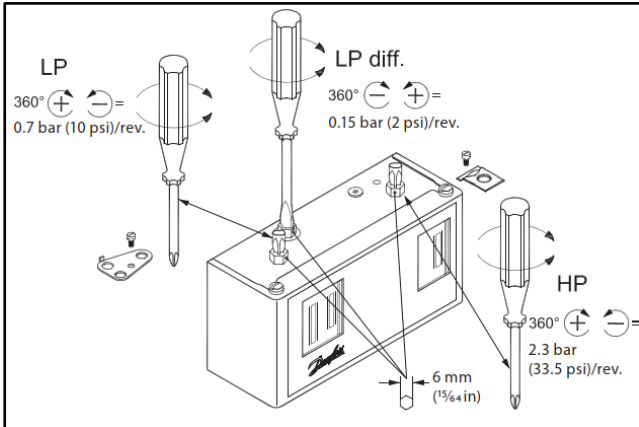

KP17WB has high pressure convertible reset feature. Insert screwdriver into the slot on the lock disc and turn it to the desired reset configuration as shown in Figure 8. Do not turn the screw on the lock disc as it may damage the convertible reset mechanism.

Figure 8: KP17WB: high pressure reset option

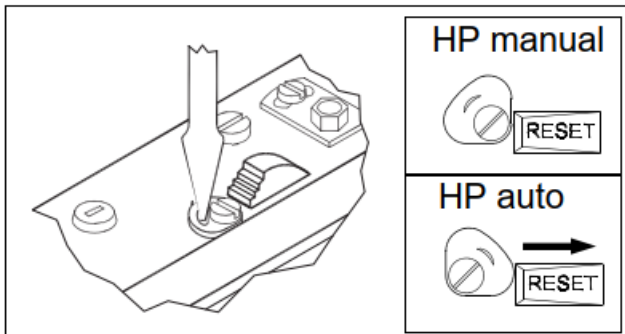

When high pressure trip is changed to auto reset on KP17WB, the compressor is ready to turn ON when discharge pressure drops below the setting value of (Cut Out – Fixed Differential).



NOTICE

When HP switch cut out mode is changed from Manual to Auto operation, the fitting of an ART (anti-recycle timer) is recommended to protect the compressor.

Table 4: Dual Pressure Switch Manufacturer Setting

Series	Model	High (barg)		Low (barg)	
		Cut Out	Diff. (Fixed)	Cut In	Diff (adj)
1,2	DNS-D306	20	7	3	2
3,4,6	KP17WB	18	4	3	2

Pressure switch settings

Both the LP and HP switch settings must be adjusted to suit application before starting the unit. Ensure that the high-pressure setting does not exceed the value shown in Table 5.

High pressure safety

- The high-pressure safety switch is required to stop the compressor should the discharge pressure exceed the compressor's high side operating pressure.
- The high-pressure switch can be set to lower values depending on the application and ambient conditions.

Low pressure protection

- The low-pressure protection cut out switch protects the compressor against deep vacuum operation, a potential cause of failure due to internal arcing and operating outside the compressor limits.
- The low-pressure protection cut out should never be set lower than the min. LP cut out value in Table 5. For systems without pump-down integrated, the LP switch signal contact shall be used to energize a low-pressure safety alarm.
- If a thermostat is used for room temperature control, and a pump down feature is not integrated, a low-pressure control of the manual reset type should be wired in series with the thermostat to serve as a protection cut-off in the event of loss of refrigerant charge or other abnormal conditions which resulting in low suction pressures.
- When used for low temperature operational control, the low-pressure control should be provided with a low differential for accurate control. For accuracy, refrigeration gauges must be used in setting cut-in and cut-out points, since the indicator on the face of the pressure switch is not sufficiently accurate for control purposes.
- Compressor operating pressures should be kept within the limits in Table 5.

Table 5: Compressor operating pressures in barg

Series	1,2	2,3,4,6		1,2	2,3,4
Application	M*			L*	
Compressor Family	AE/AJ	ZB		AJ/FH	ZF/ZFI
Refrigerant	R407A R407F R448A R449A R452A	R407A R407F R448A R449A	R134a	R448A R449A R452A	R407A R407F R448A R449A R452A
Min. LP Cut Out	1.5	2	0.6	0.1	0.3
Max. HP Cut Out	27.7		18	27.7	
LP Range	1.5~8.3	2.0~7.1	0.6~3.8	0.1~3.3	
HP Range	13.2~27.7		6.6~15.8	13.2~27.7	

*M: Medium Temperature; L: Low Temperature

Crankcase Heaters

- Crankcase heater should remain energized during the compressor off cycles. The initial start in the field is a very critical period for any new compressor because all load-bearing surfaces are new and require a short break-in period to carry high loads under adverse conditions. Thus, the crankcase heater must be turned on a minimum of 12 hours before the first-time start, to prevent oil dilution and bearing stress on initial start-up.
- To energize the crankcase heater while keeping compressor OFF, isolate the compressor from circuit by removing jumper wire which in series with H/L pressure switch, such as terminal 3-4 in Series 2, and then turn the motor rated circuit breaker to ON position.

Fan Speed Controller XGE-4C

(Applicable to Series 2/3/4 and 6)

- The fan speed controller is factory set to 19barg (maximum speed) and cut off when drop below 13barg, for operation with R4*** series refrigerant to ensure compressor always operates within the unit operating envelope.
- **When operate with R134a, the fan speed controller setting need to be set to 13bar.**

Figure 9: Full voltage adjustment on XGE-4C

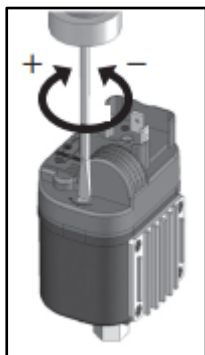

1 Turn	~1.5bar
Full voltage adjusting range	10~25barg
Full voltage set point (factory setting)	19barg full speed, mode: cut off at Pmin.
Effective proportional band	6 barg (fixed)

- The FSC is set according to Table 6 to gain higher energy efficiency as published in the Ecodesign data sheets.

Table 6: FSC settings to obtain eco design data

Model	FSC settings (barg, maximum speed)	
	R407A, R407F, R448A, R449A, R452A	R134a
S2 except (JEHS-0350-B2-M; JEHR-0180/210-B2-L)	19	13
JEHS-0350-B2-M; JEHR-0180/210-B2-L; S3	10	13
S4 except EVI; S6	10	10
S4 EVI	17	N/A

Fan control switch SYS-C130

(Applicable to Series 1- Low Temperature Model)

- The fan control switch is factory set as Table 7, which is the same setting to obtain the Eco design data.
- Fan stopped when the pressure drop below fan cut out pressure.

Table 7: Fan control switch factory setting

Model	Fan control Switch (barg)	
	Cut in	Differentiate
JEHR-0115/135-B1-L-1	16	7

Fan Cut Out = Cut In – Differentiate

Discharge Thermostat

(Applicable to JEHS-0750-B4-L-3, JEHS-1300-B4-M-3, JEHS-1500-B6-M-3 and all EVI)

Only scroll models specified above are equipped with discharge thermostat with specification (cut out = $125 \pm 4^\circ\text{C}$, cut in = $95 \pm 5^\circ\text{C}$). The thermostat is connected in series to dual pressure switches, to disconnect all three phases at contactor in case of overtemperature.

For other 3phase models, it is recommended to install the discharge thermostat with cut out **temperature not more than the maximum discharge gas temperature specified in Table 2.**

Overheating could be due to compressor working at high compression ratio (low evaporating and high condensing pressure); loss/ inadequate charge; or condenser fan not working. Time must be allowed for the compressor to cool down before the thermostat auto reset.

For scroll compressors with motor protection code "F", an internal line break motor protector is located at the center of the Y of the motor windings (motor located in low pressure dome), to disconnect all three phases in case overcurrent or overtemperature condition. The protector is the automatic reset device containing snap action bimetal switch which reacts to a combination of motor current and motor windings temperature. When the internal motor protector has tripped, it will take 30 to 40 minutes to reset and then the compressor will restart.

On a field application, when the internal motor protector has tripped, the compressor will stop while each of 3 terminals is still energized, to which either the customer or serviceman may regard the compressor as fail down. Therefore, the above-mentioned situation should be taken into consideration.

Units with microchannel condenser

- Care must be taken during charging a unit where a microchannel condenser coil is fitted.
- The microchannel coils hold less refrigerant than traditional fin/tube coils, it is easier to be overcharged, especially if the system is commissioned during wintertime which ambient temperature is colder.
- If too much refrigerant is added, this may cause tripping of the high-pressure switch in warmer weather.
- Always check that the amount of condenser sub cooling is not excessive which may indicate refrigerant overcharge.

System operation

- Once the system is correctly charged with refrigerant and the operating condition is stable, check that the compressor suction superheat is between 10K~20K and that the compressor discharge temperature is between $50^\circ\text{C} \sim 90^\circ\text{C}$.
- A compressor suction superheat that is too low may indicate liquid refrigerant return to the compressor,

whereas a suction superheat that is too high will not provide enough cooling effect for the compressor and will cause high discharge temperatures. In either case, it is likely that compressor damage/failure will occur.

Precautions when operate with FH and AJ Compressor

Follow instructions below when operating R448A/R449A in low temperature condensing unit which integrated with Tecumseh compressor FH/AJ.



NOTICE

Limit the suction superheat below 10K, to ensure discharge temperature is maintained below 120°C with evaporating temperature of -30°C and below. Do not use capillary tubes as throttling devices to prevent plugging issue.

Voltage Monitoring Device MG73BF

(Applicable to JEHS-1400-B4-L-3 EVI; JEHS-1300-B4-M-3 and JEHS-1500-B6-M-3 units only)

Only the above models are equipped with voltage monitoring device to monitor the input power supply to protect the 3-phase compressor from overheating as result of working under phase lost, undervoltage or overvoltage.

Table 8: LED indication on front plate of MG73BF

LED (ON/OFF) Condition	LED			
	ON	UV	OV	BLINK: ASY, ON: REV
Power ON	ON	OFF	OFF	OFF
Phase reverse	ON	OFF	OFF	ON
Asymmetry	ON	OFF	OFF	BLINK
Under voltage	ON	ON	OFF	OFF
Over voltage	ON	OFF	ON	OFF
Phase Fail	BLINK	OFF	OFF	OFF
Phase Fail when input voltages lower than UV set point and below asymmetry	BLINK	ON	OFF	BLINK
Neutral Fail	ON	BLINK	BLINK	BLINK

The off-delay timer will turn the system off after a set amount of time for following situation:

- Supply phases exceed over voltage or under voltage trip level setting
- Any supply phase failure
- Line interruption
- Phase reverse occurrence
- Neutral failure



Vapor Injection Controller EXD-HP1

(Applicable to EVI units only)

The controller EXD-HP1 used in the EVI units operates as an **economizer control**. The setting of the controller is factory pre-set and is password protected. Users are not recommended to change any settings in the controller.



CAUTION

Electronic expansion valves in the EVI unit are in partially open condition. Do not charge the system with refrigerant before closure of valve.

Four main parameters Password (H5), type of function (1uE), refrigerant type (1u0) and pressure sensor type (1uP) can be set only when digital input DI1 is off (open) while the power supply is ON (24Vac).

Digital input Di1

- The digital status is dependent on the operation of system's compressor or demand.

Table 9: Digital input status of EXD-HP1

Operating Condition	Di1 status
Compressor starts	Closed (Start)
Compressor stops	Open (Stop)

Electrical checked/modified before start-up

- To fully close the EEV, open circuit Di1-gnd of controller through disconnecting the supply to compressor. For
 1. Model JEHS-0951/1150-B4: remove the jumper wire from terminal block labeled 8 and 9.
 2. Model JEHS-1300-B5: remove twin jumper bars from terminal blocks labelled 6 and 7.
- Switch ON the motor rated circuit to turn ON the power supply 24V to the controller EXD-HP1. The valve will be driven to a close position.
- After closure of the EEV valve, start charging the system with refrigerant.
- Disconnect power supply through motor rated circuit breaker, then reconnect back the original wiring from factory.
- Do not apply voltage to the system before all cable connections are completed.
- Use a class II category transformer for 24 Vac power supply. Do not ground the 24 Vac lines.
- Higher voltage than specified will permanently damage the controller.
- When connecting wires of EEV and pressure sensor 4~20mA to the controller EXD-HP1, follow the cable color to connect to the respective abbreviation color code printed on the EXD-HP1. Example for EXV: BR = Brown; BL = Blue etc. Or refer to wiring diagram for electrical connections.

Figure 10: Display/ keypad unit (LEDs and button functions)

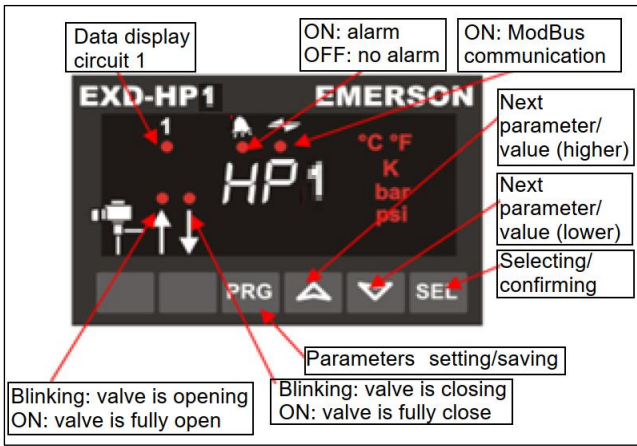

- In the case of economizer control. The **discharge temperature** is shown on the display.
- To display other **MEASURED DATA** on EXD-HP1, press “SEL” button for 1 second until index number according to below table appears. Release “SEL” button and the next variable data will be displayed. Repeating the procedure to view all variable data in sequence:

Table 10: Display parameters

Display Index	Variable Data
10	Default Superheat, K
11	Suction pressure, bar
12	Valve position, %
13	Suction gas temperature, °C
14	Saturation temperature, °C
15	Discharge temperature, °C

Note: After 30minutes, the display reverts to index 10.

Table 12: EXD-HP1 error/ alarm handling

Alarm code	Description	Related parameter	Alarm relay	Valve	What to do?	Requires manual reset after resolving alarm
1E0/2E0	Pressure sensor 1/2 error	-	Triggered	Fully close	Check wiring connection and measure the signal 4 to 20 mA	No
1E1/2E0	Temperature sensor 1/2 error	-	Triggered	Fully close	Check wiring connection and measure the resistance of sensor	No
1Ed	Discharge hot gas temperature sensor 3 error	-	Triggered	Operating	Check wiring connection and measure the resistance of sensor	No
1P-2P-	EXM/EXL or EXN electrical connection error	-	Triggered	-	Check wiring connection and measure the resistance of winding	No
1Ad	Discharge hot gas temperature above limit	-	Triggered	Operating	Check valve opening/ check liquid flow for flash gas free/check discharge hot gas temperature sensor	No
1AF/2AF	Freeze protection	1P4/2P4: 1	Triggered	Fully close	Check the system for cause of low pressure such as insufficient load on evaporator	No
1AF/2AF blinking		1P4/2P4: 2	Triggered	Fully close		Yes
1AL/2AL	Low superheat (<0.5K)	1uL/2uL: 1	Triggered	Fully close	Check wiring connection and operation of valve	No
1AL/2AL blinking		1uL/2uL: 2	Triggered	Fully close		Yes
1AH/2AH	High superheat	1uH/2uH: 1	Triggered	Operating	Check the system	No
1AP/2AP	Low pressure	1P9/2P9: 1	Triggered	Operating	Check the system for cause of low pressure such as refrigerant loss	No
1AP/2AP blinking		1P9/2P9: 2	Triggered	Operating		Yes
1Ai	High injection pressure circuit 1	1E7 / 1E8	Triggered	Operating	Check the system	No
Err	Failed uploading/downloading	-	-	-	Repeat again the procedure for uploading/downloading	No

Note: When multiple alarms occur, the highest priority alarm is displayed until being cleared. Then the next highest alarm is displayed until all alarms are cleared. Then, the parameters will be shown again.

Manual mode operation

- Manual mode is intended for **temporary operation** of the valve at specific condition. Warning: All alarms are disabled during manual operation. We do not recommend unattended operation of the system during manual control.
- Press **PRG** and **↓** together for 5seconds to access to manual mode operation.
- After achieving the required operation, set the parameter 1Ho and 1HP at 0, so the controller automatically operates the valve at its setpoints.
- List of parameters in scrolling sequence by pressing **↓** button

Table 11: Parameter list for manual mode operation

Code	Parameter description and choices	Min	Max	Factory setting
	Manual mode operation; circuit 1			
1Ho	0 = off 1 = on	0	1	0
1HP	Valve Opening (%)	0	100	0

Manual alarm reset clearing functional alarms (except hardware error)

- Press **PRG** and **SEL** together for 5seconds. When the clearing is done, “CL” message appears for 2 seconds.

Outline Drawing

Figure 11: Outline Drawing Series 1

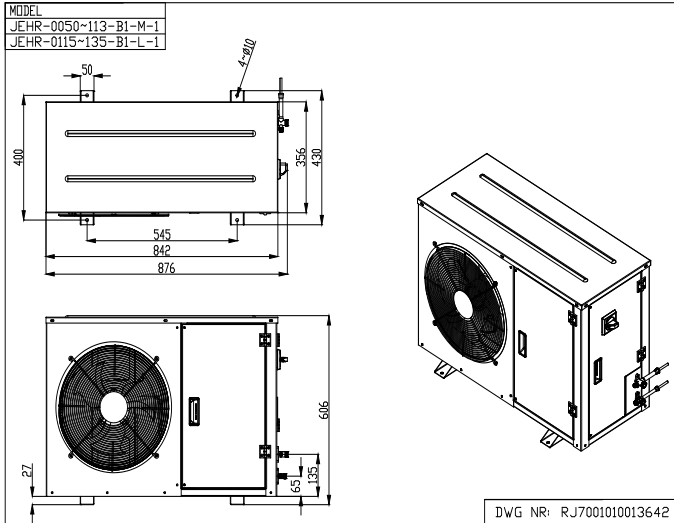

Figure 12: Outline Drawing Series 2

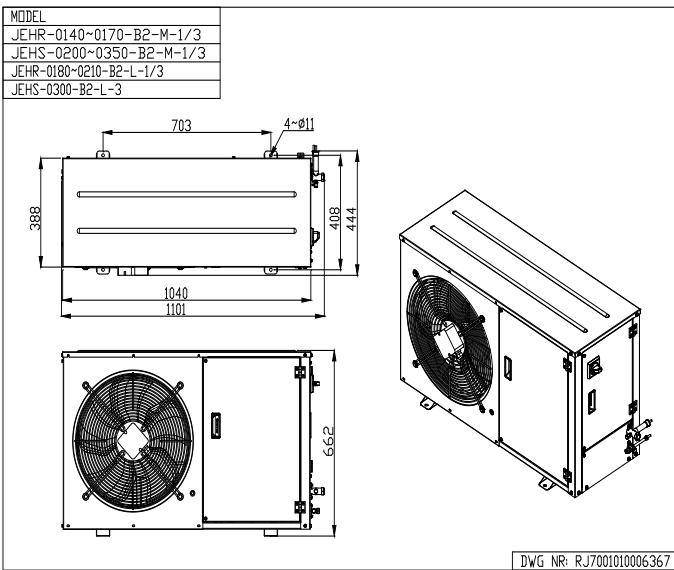

Figure 13: Outline Drawing Series 3

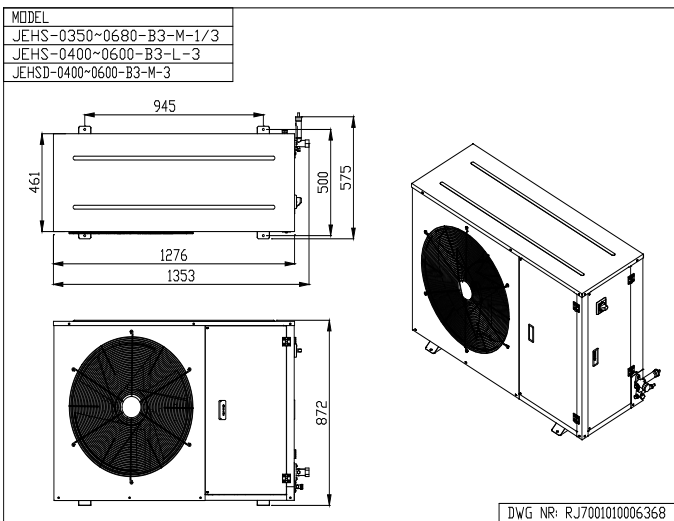

Figure 14: Outline Drawing Series 4

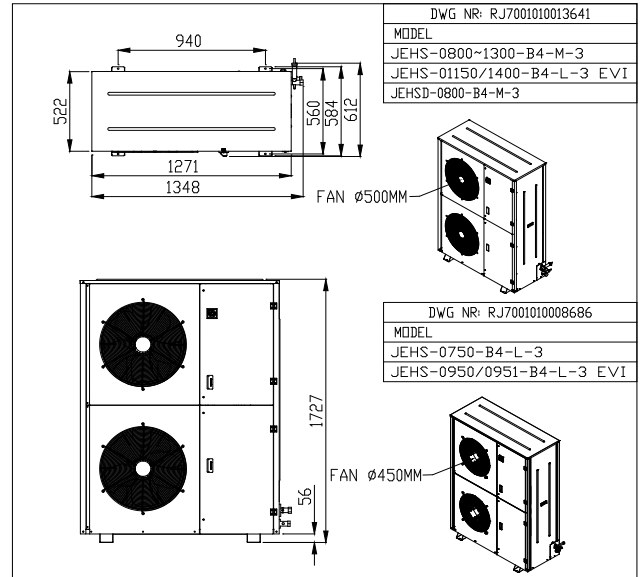
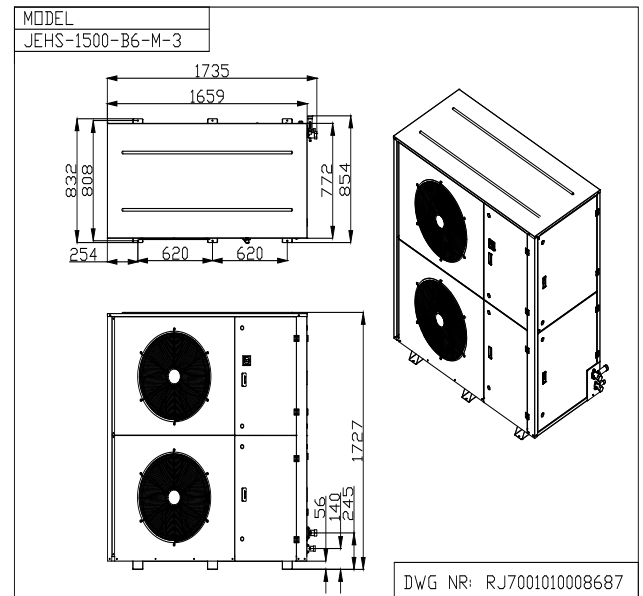

Figure 15: Outline Drawing Series 6



Wiring Diagrams

Figure 16: JEHR-0050-B1-M-1

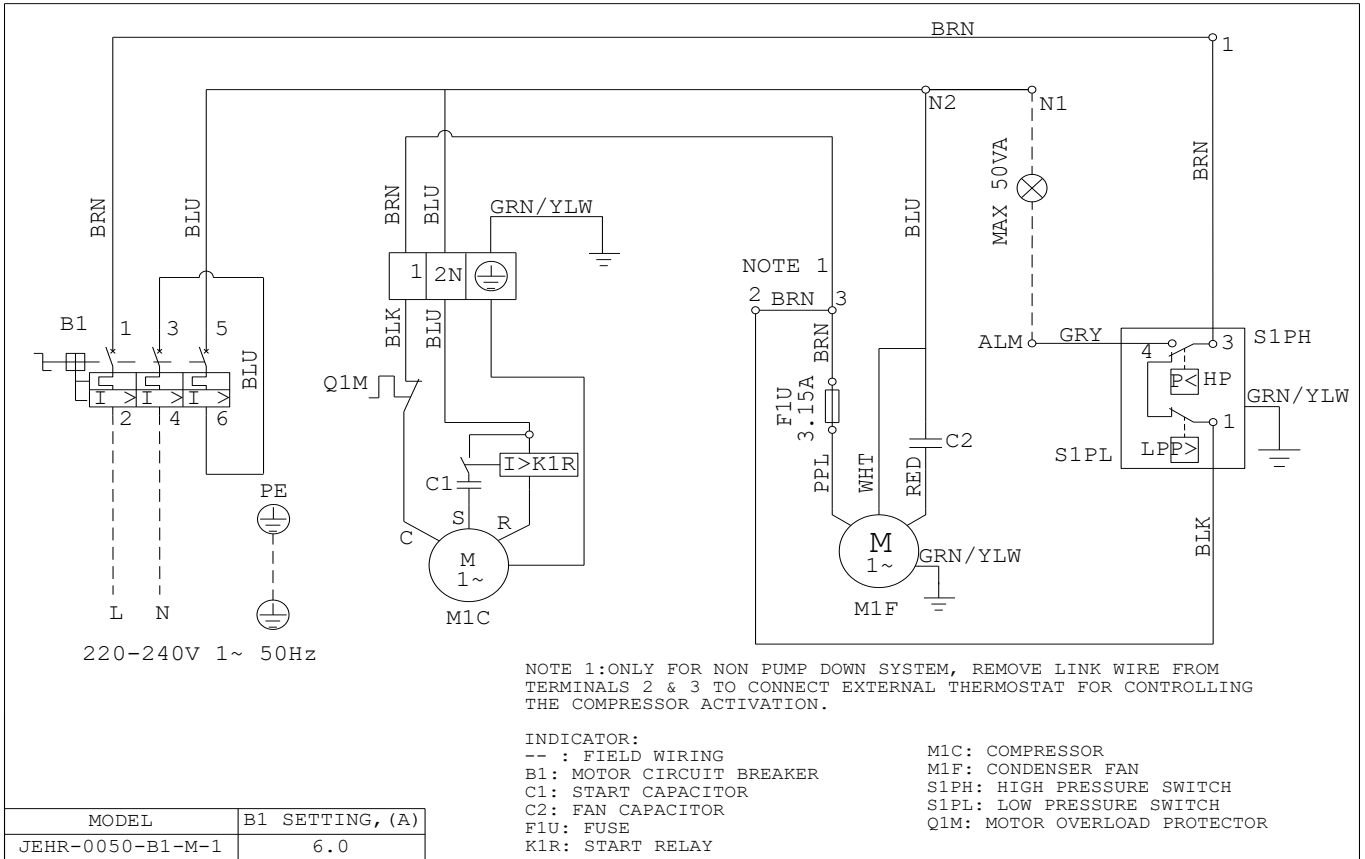

Figure 17: JEHR-0067/0100/0113-B1-M-1

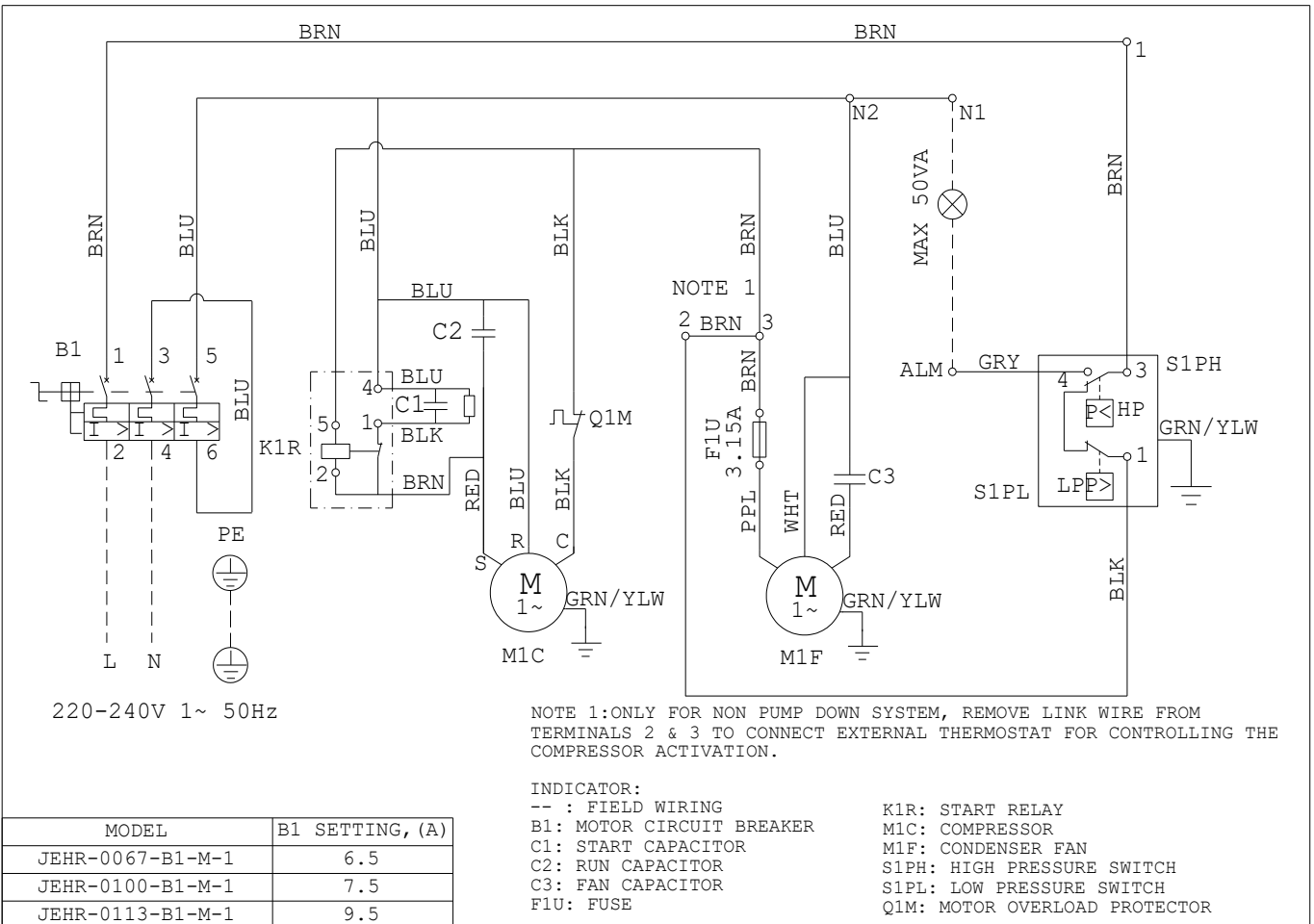

Figure 18: JEHR-0115/0135-B1-L-1

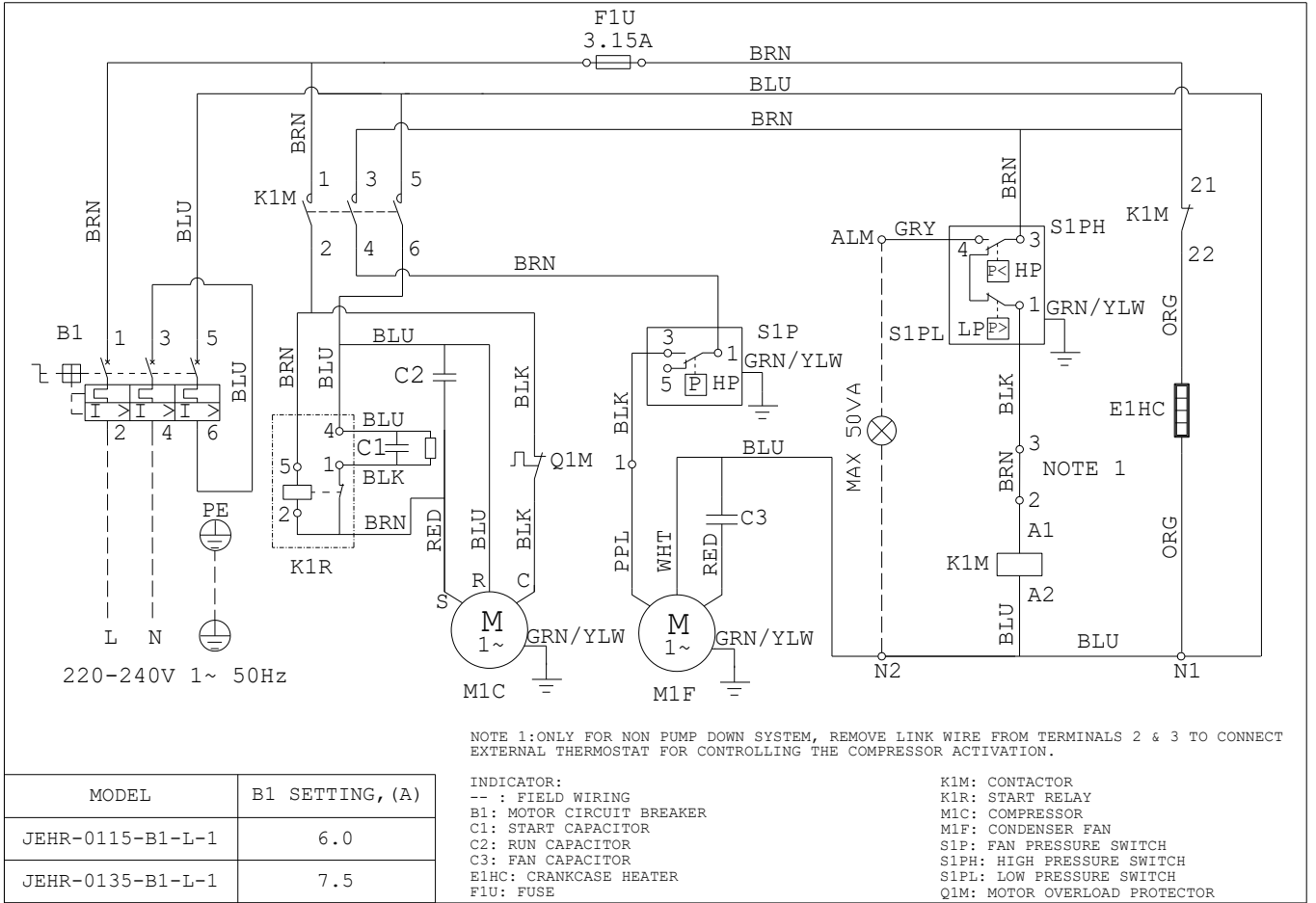

Figure 19: JEHR-0140/0170-B2-M-1

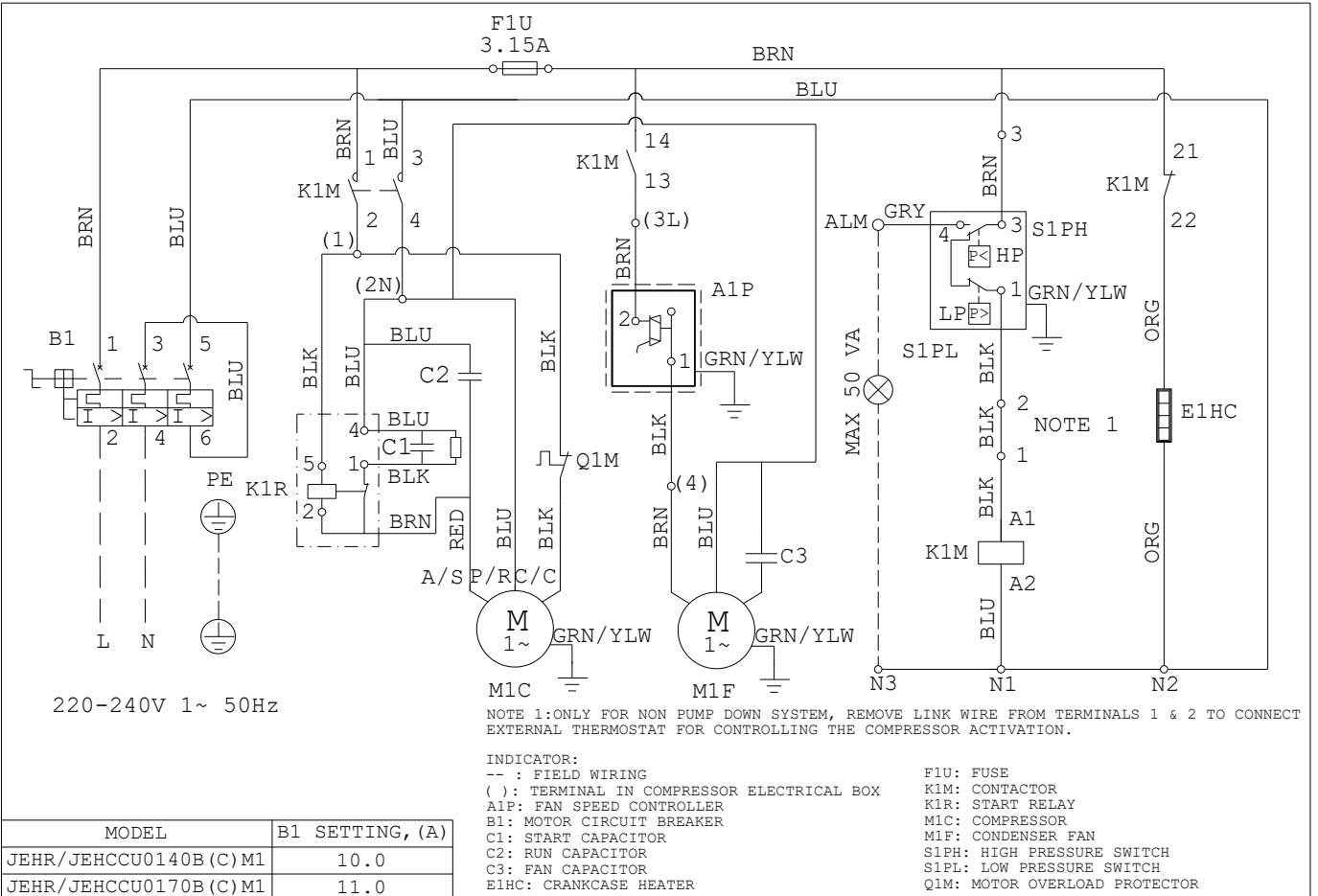

Figure 20: JEHR-0140/0170-B2-M-3

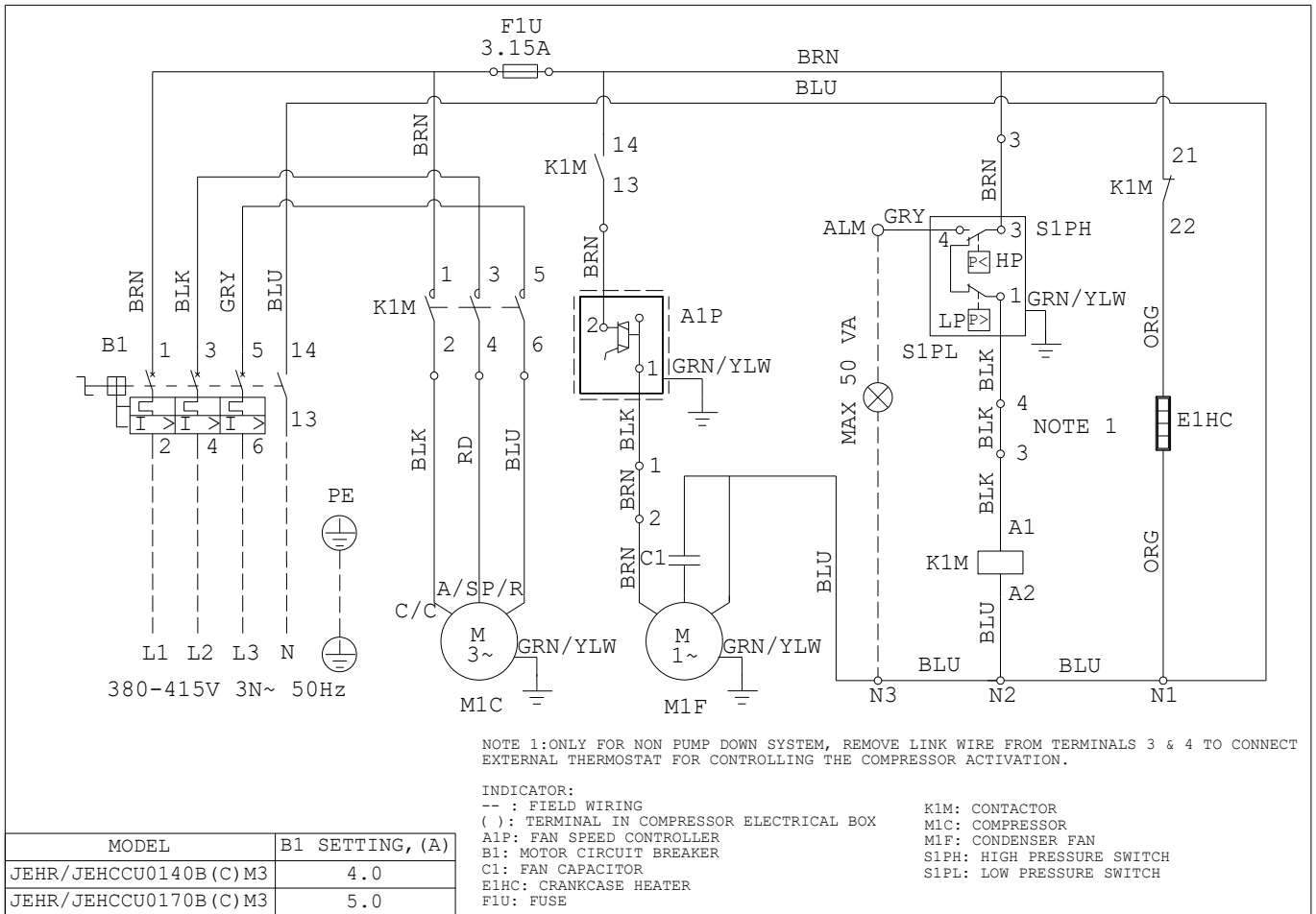

Figure 21: JEHR-0180/0210-B2-L-1

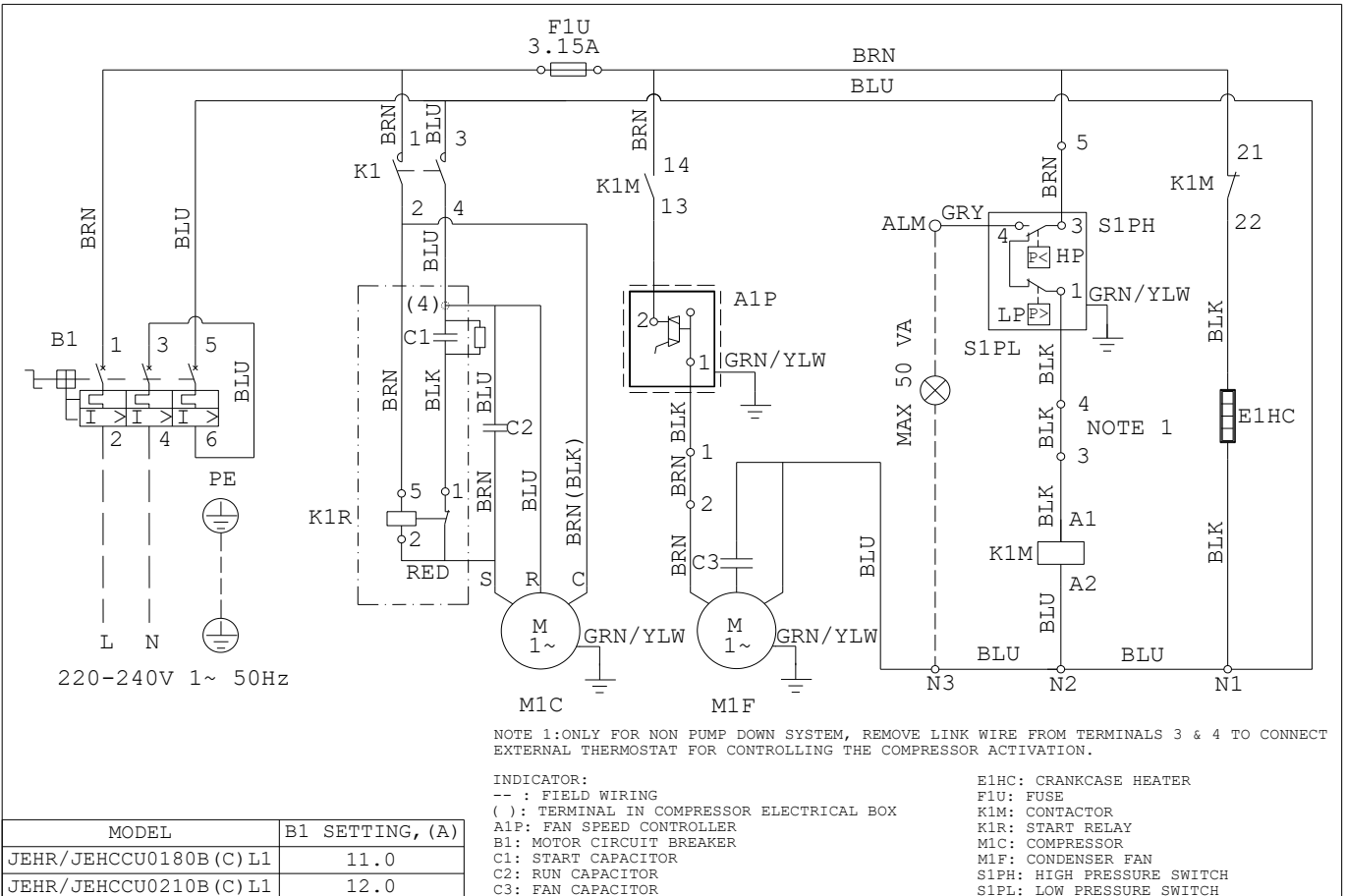

Figure 22: JEHR-0180/0210-B2-L-3

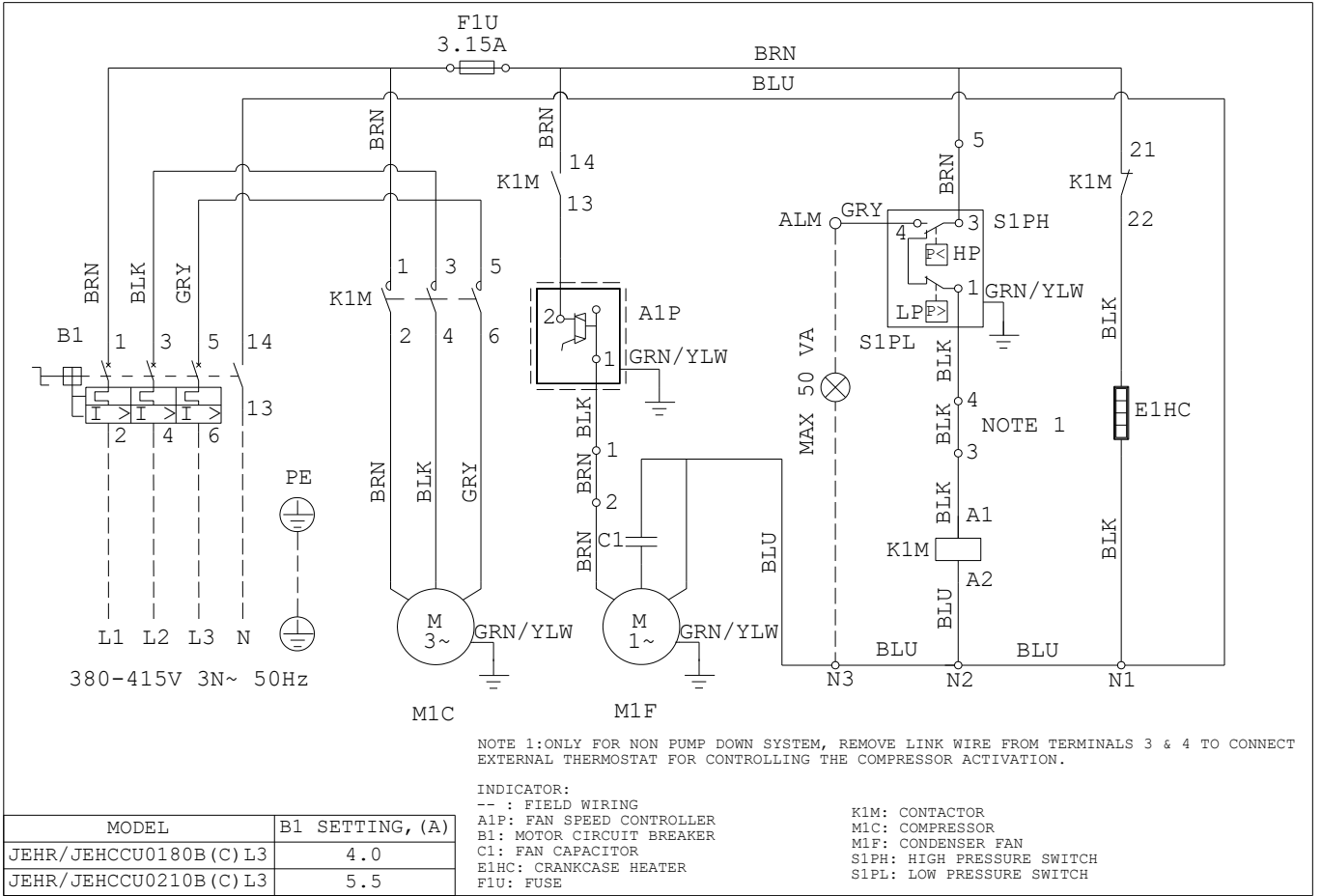

Figure 23: JEHS-0200/0250/0300/0350-B2-M-1

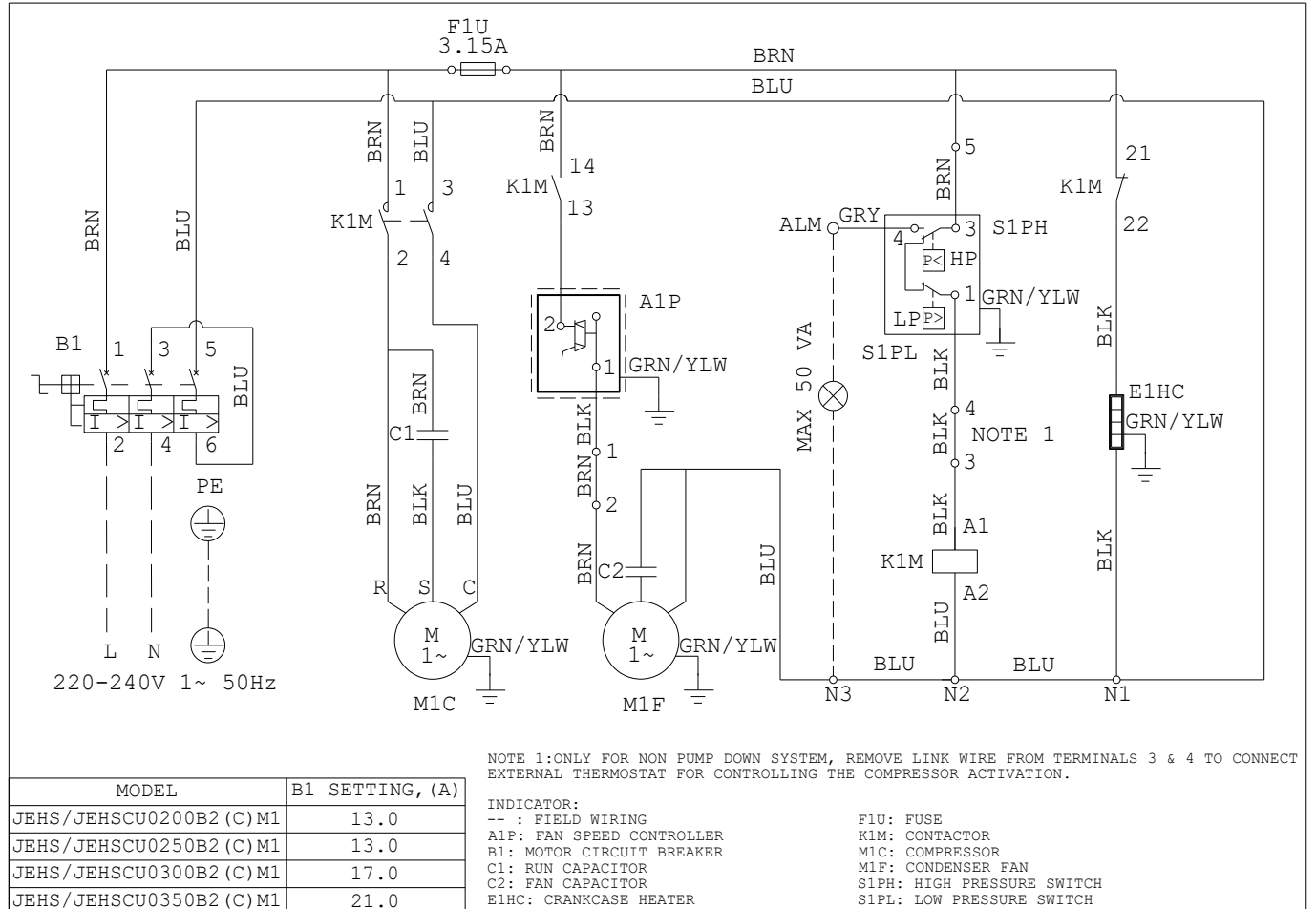

Figure 24: JEHS-0200/0250/0300/0350-B2-M-3, JEHS-0300-B2-L-3

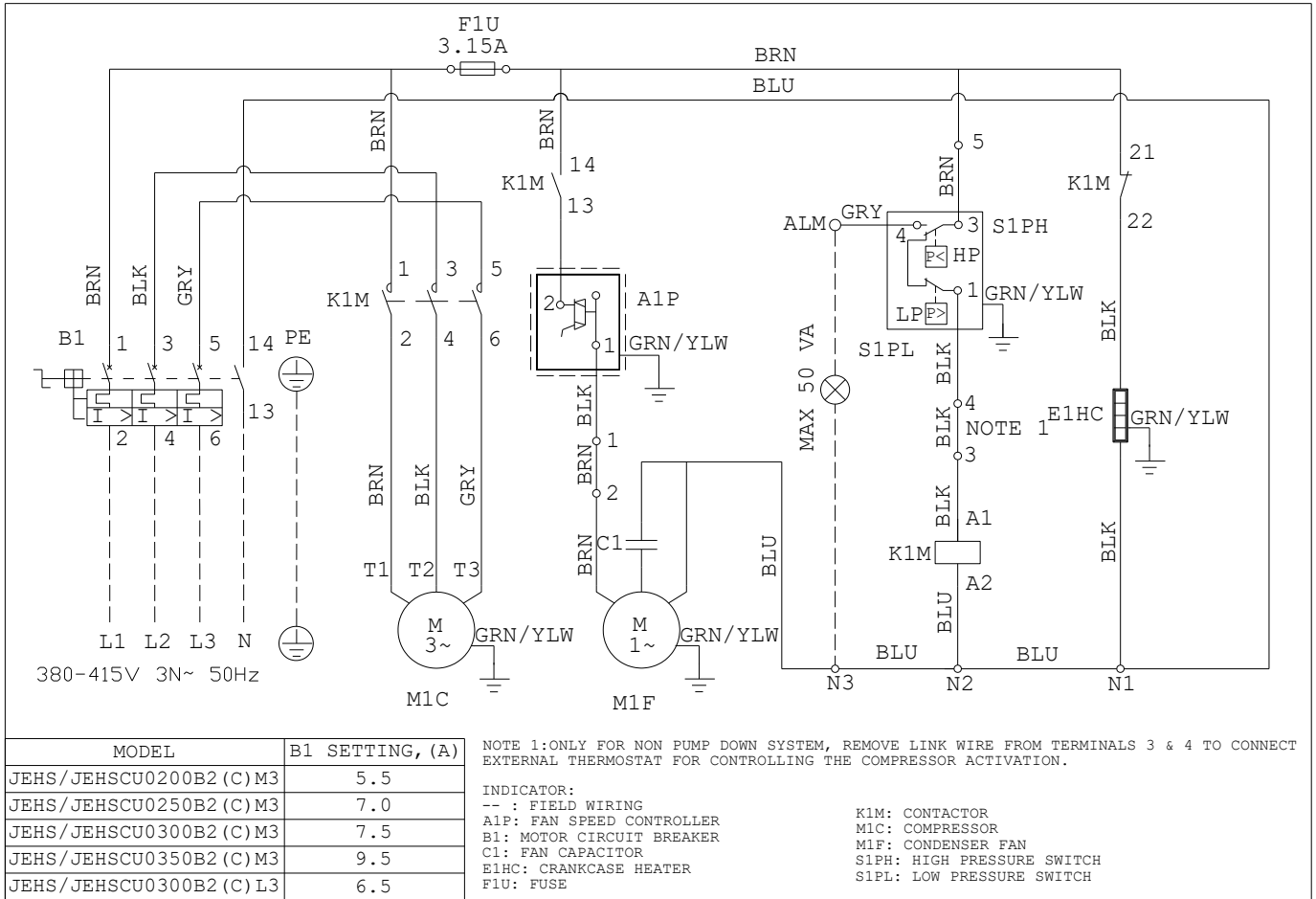

Figure 25: JEHS-0350/0400-B3-M-1

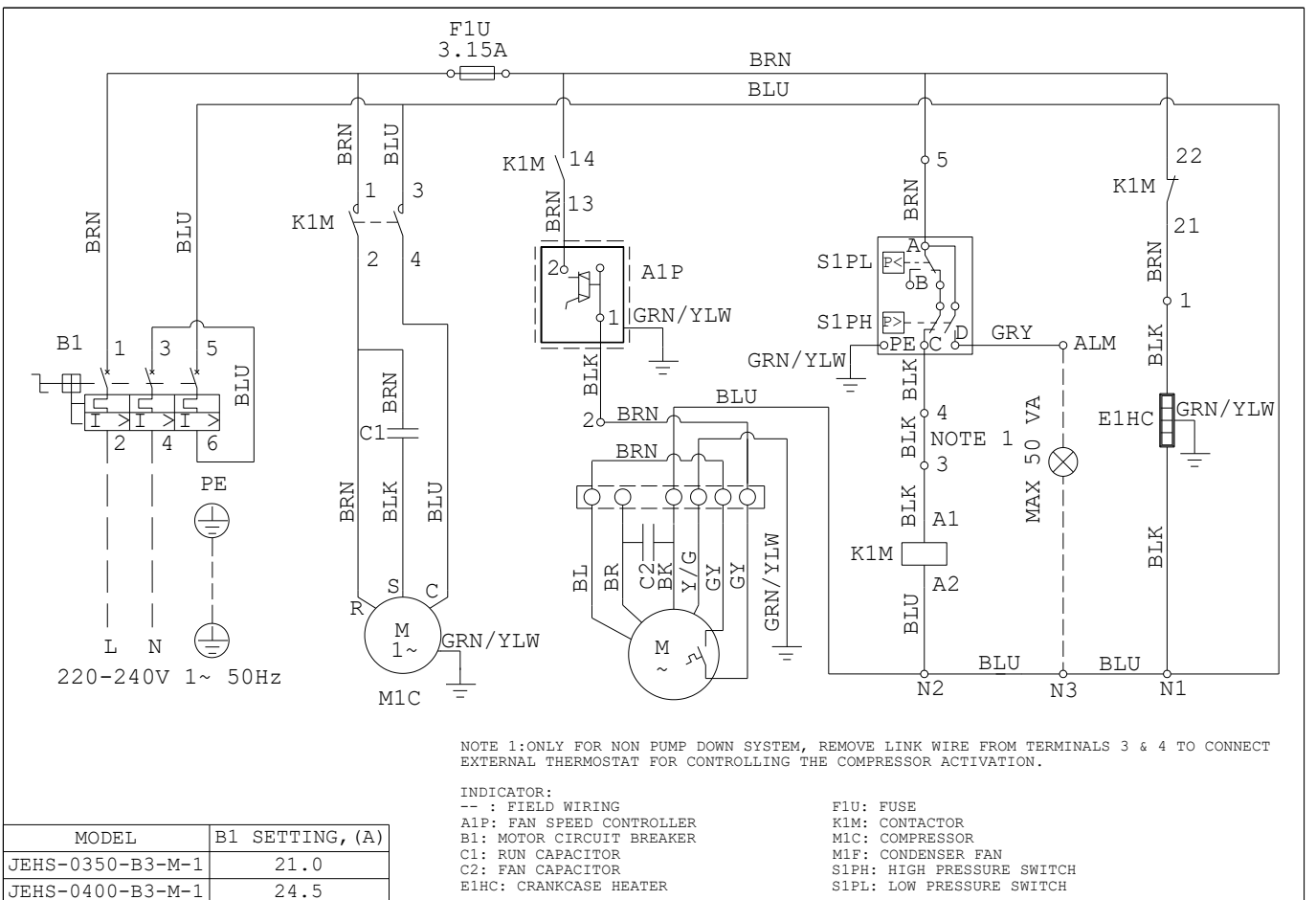

Figure 26: JEHS-0350/0400/0500/0600/0680-B3-M-3, JEHS-0400/0500/0600-B3-L-3

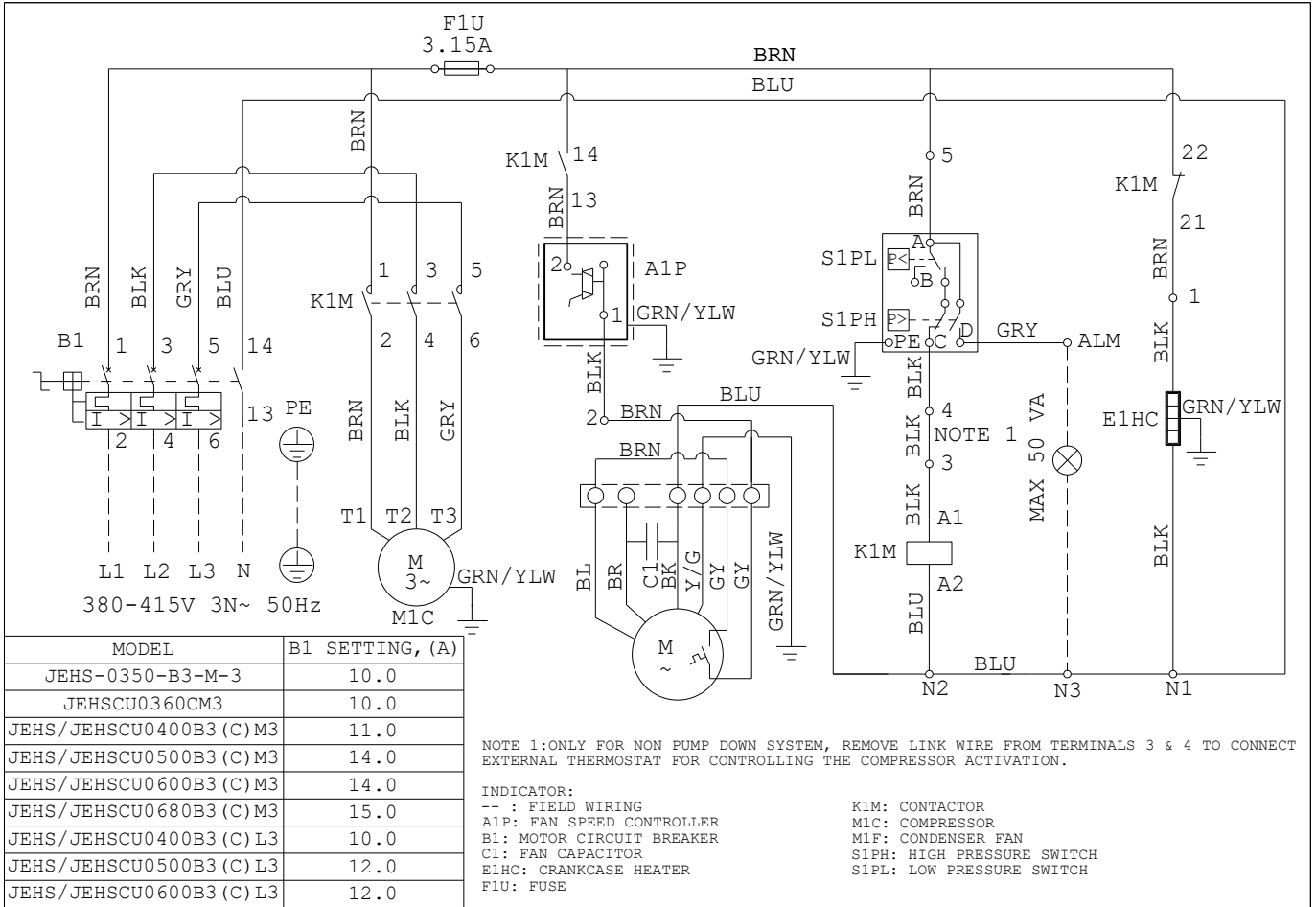

Figure 27: JEHS-0800/1000-B4-M-3

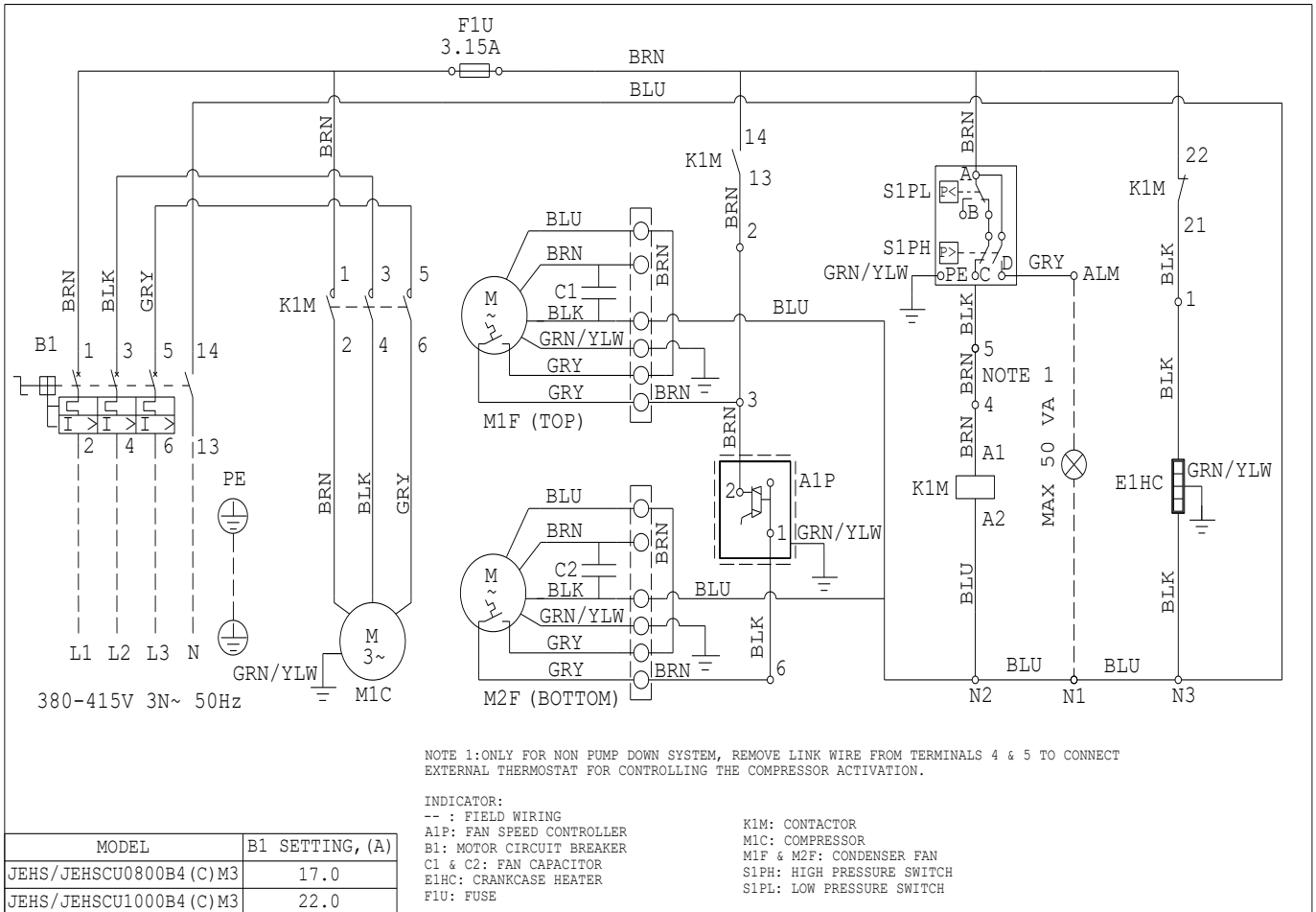

Figure 30: JEHS-0951-B4-L-3 EVI

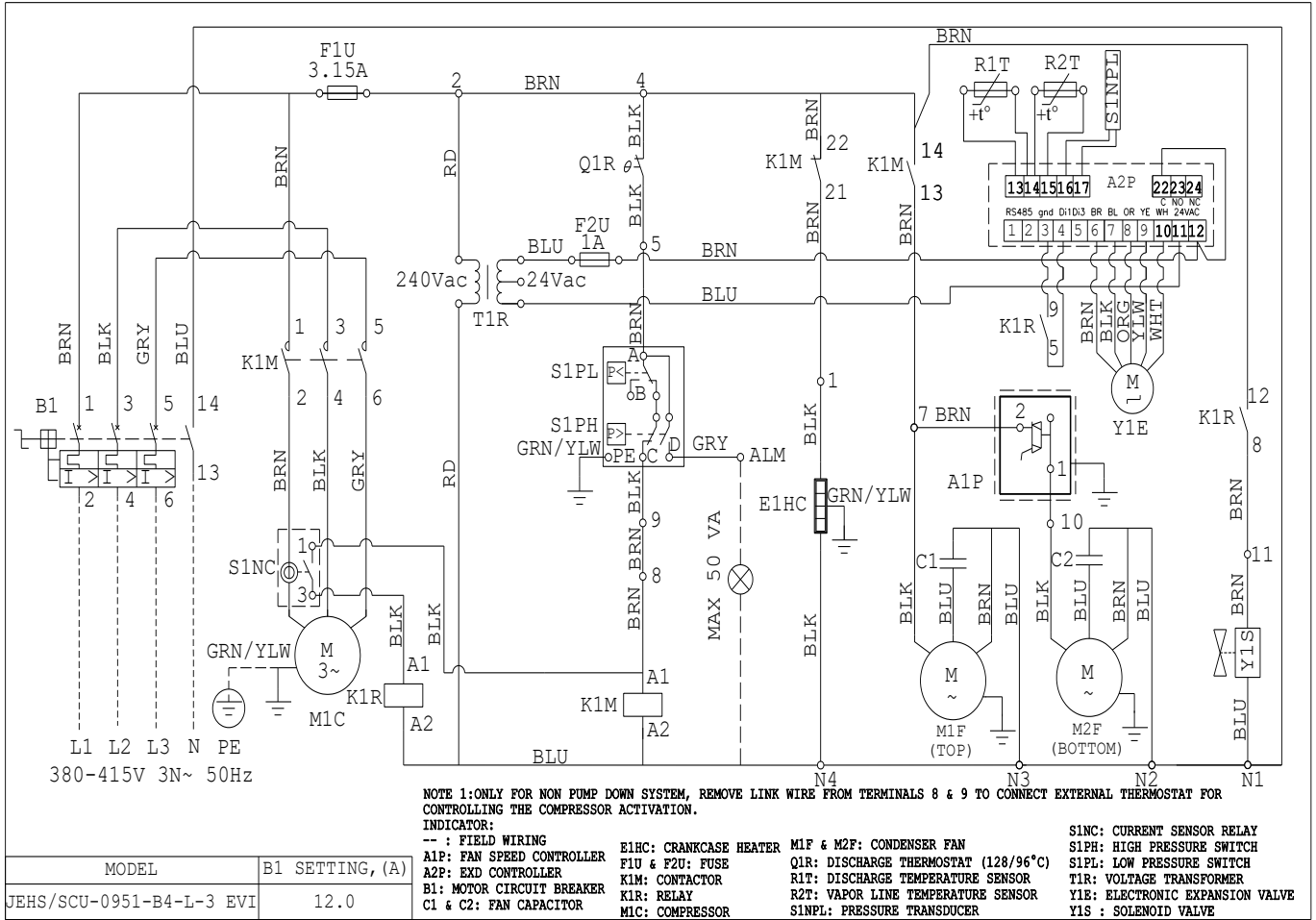

Figure 31: JEHS-1150-B4-L-3 EVI

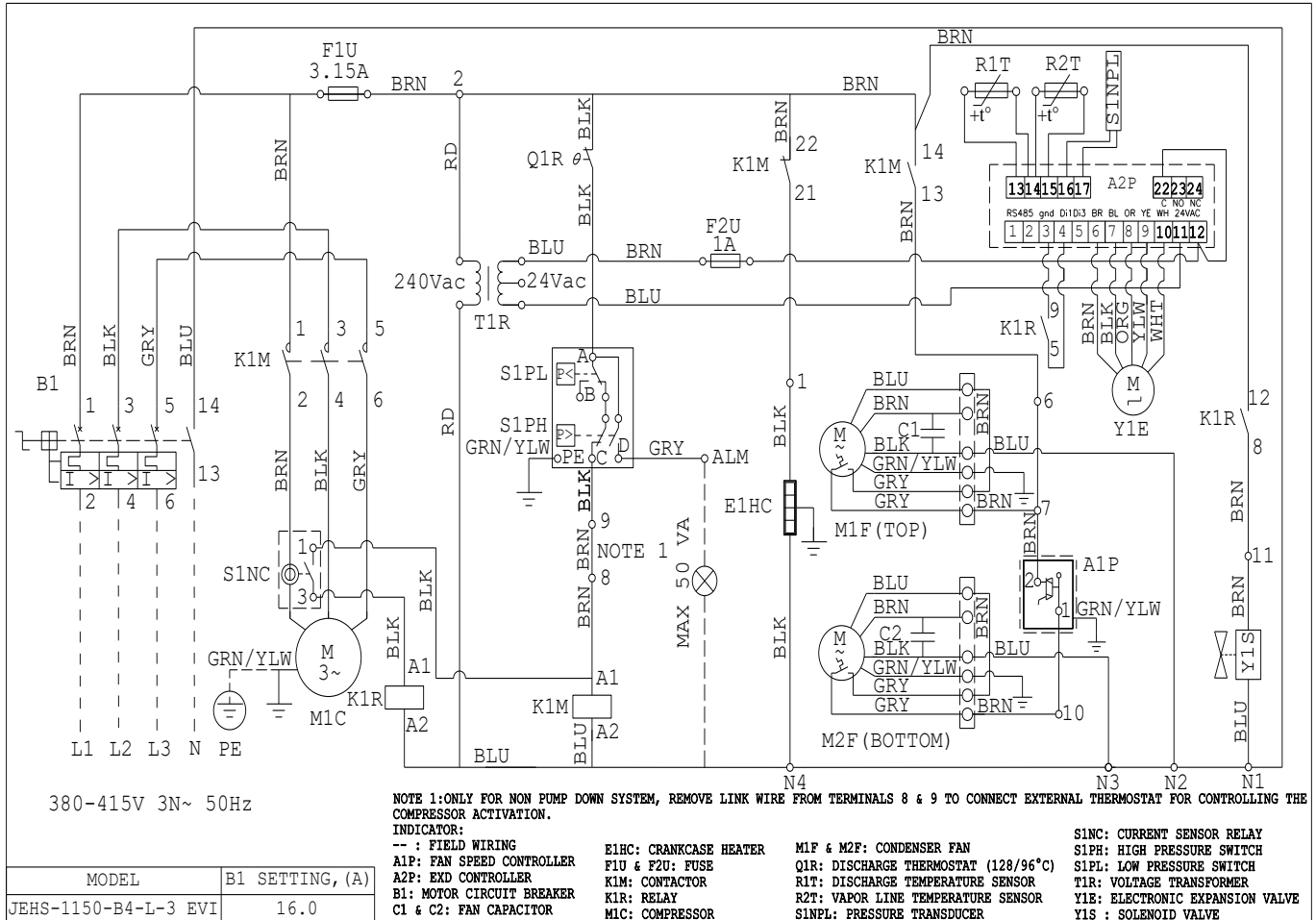
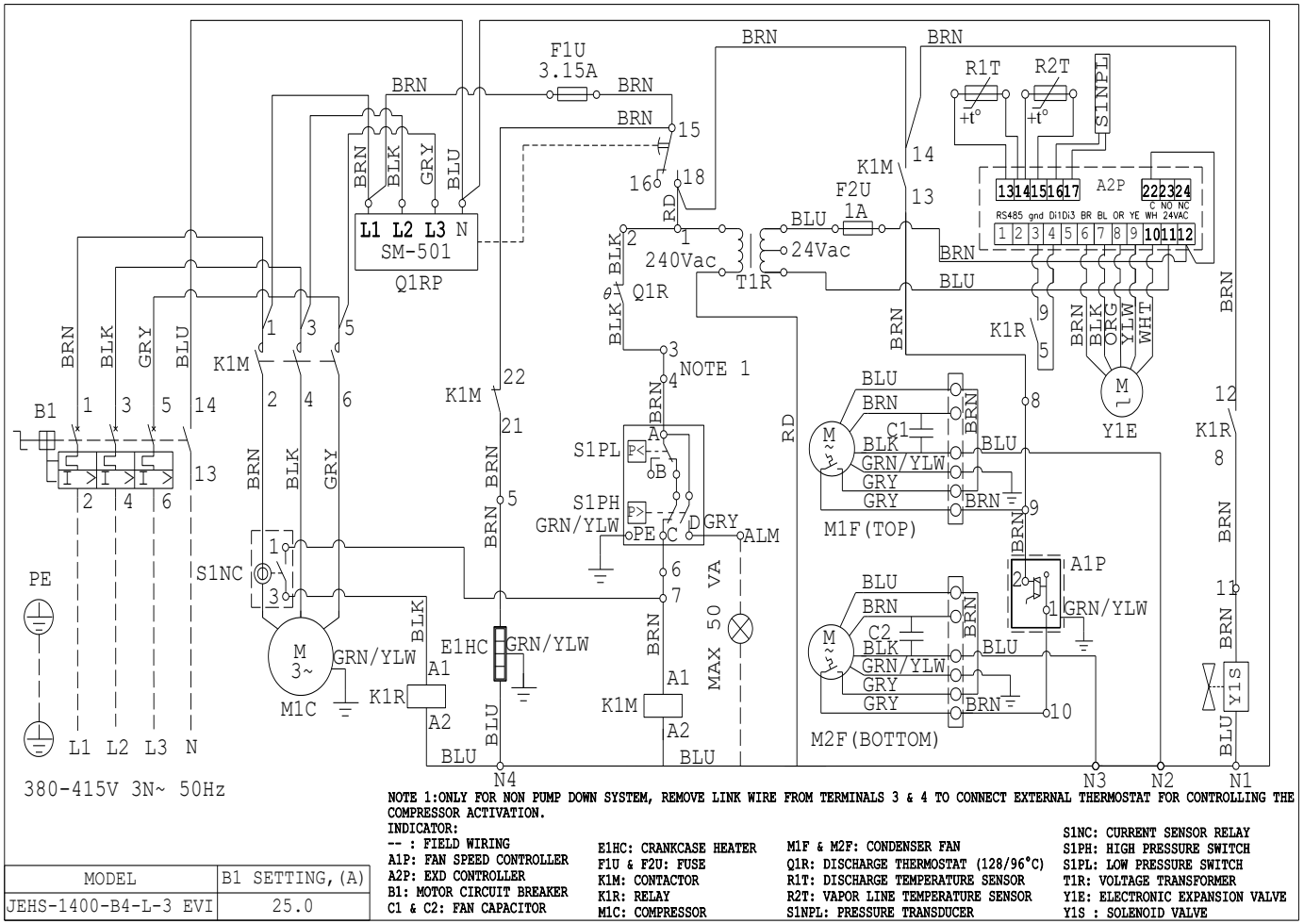

Figure 32: JEHS-1400-B4-L-3 EVI



Service & Maintenance



WARNING

Disconnect the mains electrical supply before servicing or opening the unit.

The condensing units are designed to give long life operation with minimum maintenance. However, they should be routinely checked, and the following service schedule is recommended under normal circumstances:

The removal of the top, side and front panels ensures that all parts are accessible.

1. Compressor – Inspect at regular intervals

- Check for refrigerant leaks on all joints and fittings.
- Check mountings for tightness and wear.
- Check operation of crankcase heater.
- Check electrical connections.
- Ensure that no abnormal noise or vibration is detected during test run.
- Check the compressor oil levels and top up if required. The oil level should be $\frac{1}{2}$ to $\frac{3}{4}$ way up the sight glass (where fitted).

2. Condenser Fan Motor & Blade – Clean and inspect at regular intervals

- Check for abnormal noise, vibration, and fan imbalance.
- Ensure that the fan motor is clean and spins freely.
- Check that the condenser fan blade is clean and free from restriction and damage/imbalance.
- Note: The fan motor is pre-lubricated, and factory sealed so no maintenance is necessary.

3. Microchannel Condenser Coil – Clean and inspect at regular intervals.

- Remove surface dirt, leaves etc. with a vacuum cleaner (preferably with a brush or other soft attachment rather than a metal tube), compressed air blown from the inside out, and/or a soft bristle (not wire!) brush. Do not impact or scrape the coil with the vacuum tube, air nozzle, etc.
- Do not use any chemicals (including those advertised as coil cleaners) to wash micro channel heat exchangers. They can cause corrosion. Rinse only. Hose the MCHE off gently, preferably from the inside out and top to bottom, running the water through every fin passage until it comes out clean. Micro channel fins are stronger than traditional tube & fin coil fins but still need to be handled with care. Do not bang the hose into the coil. We recommend putting your thumb over the end of the hose rather than using a nozzle end because the resulting spray is gentler and the possibility for impact damage is less.
- Micro channel heat exchangers, because of their fin geometry, tend to retain water more than traditional fin & tube coils. Depending on the specific design and installation of your coil, it may be beneficial to blow or vacuum out the rinse water from your unit to speed drying and prevent pooling.

4. Compact Brazed Heat Exchanger (BPHE)

**** For EVI Units ONLY**

- Any soldering process done on the heat exchanger needs to be brazed with a minimum of 45% silver solder at maximum 450°C (840°F) when soft

soldering and 450-800°C (840-1470°F) when hard soldering.

- Do not direct flame at BPHE and use wet rag to avoid overheating of BPHE.

5. Controls

- Check settings and operation of pressure switches.
- Check overload setting.
- Check fan speed control setting and operation.

6. Power Supply – Inspect at regular intervals.

- Check the running current and voltage for the condensing unit.
- Check the electrical wiring and tighten the wires onto the terminal blocks if necessary.

7. Refrigerant Charge

- Check the refrigerant charge by ensuring that the system is operating correctly, the pressures are as expected and that the liquid line sight glass shows a full bore of liquid refrigerant.
- Carry out a full leak test.

8. Compressor replacement (rotalock connections)

- The rotalock connections used on some compressor models are factory sealed with Loctite 554 thread sealant. If the rotalock connections need to be disassembled (e.g., compressor change), then they should be thoroughly cleaned and Loctite 554 reapplied before reassembly. In case of difficulty undoing the connections due to the sealant, apply heat to the rotalock using a heat gun for several minutes and then loosen using hand tools whilst hot. Replacement of the 'O' ring seal may be required. Please see *Table 13* for the recommended torque tightening values.

9. Unit decommissioning and disposal

- At the end of the unit's useful life, a suitably qualified engineer should decommission it. The refrigerant and compressor oil are classed as hazardous waste and as such must be reclaimed and disposed of in the correct manner, including completion of waste transfer paperwork. The unit components must be disposed of or recycled as appropriate in the correct manner.

10. Warranty

- The warranty as provided by J & E Hall on its products is subject to correct application, siting, and installation procedures together with subsequent recorded maintenance/servicing carried out in accordance with our recommendations. Failure to do so could result in the withdrawal of our warranty.

Please go to our website for our detailed warranty terms and conditions: www.jehall.co.uk

Table 13: Torque Tightening

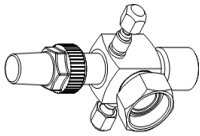
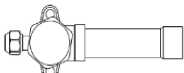
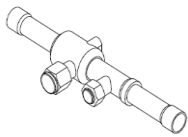
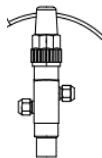
Model	Tightening Torque (Nm)							
	Compressor Rotalock Valve		Service Valve		Ball Valve		Liquid Receiver	Schrader Valve; Charging port
	Suction	Discharge	Suction	Liquid	Discharge	Liquid		
JEHR-0050-B1-M-1	Not Applicable (Braze Connection)		M16*1.0mm (20-25 Nm)	M18*1.0mm (25-30 Nm)	N/A			
JEHR-0067-B1-M-1								
JEHR-0100-B1-M-1								
JEHR-0113-B1-M-1								
JEHR-0140-B2-M-1								
JEHR-0140-B2-M-3								
JEHR-0170-B2-M-1	Not Applicable (Braze Connection)		M22*1.0mm (30-35 Nm)	M16*1.0mm (20-25 Nm)		M14*1.5mm (25-30Nm)	Braze Connection Plug 3/8"NPT (18-22Nm)	
JEHR-0170-B2-M-3								
JEHS-0200-B2-M-1								
JEHS-0200-B2-M-3								
JEHS-0250-B2-M-1								
JEHS-0250-B2-M-3								
JEHS-0300-B2-M-1								
JEHS-0300-B2-M-3								
JEHS-0350-B2-M-1								
JEHS-0350-B2-M-3								
JEHS-0350-B3-M-1								
JEHS-0350-B3-M-3								
JEHS-0400-B3-M-1								
JEHS-0400-B3-M-3								
JEHS-0500-B3-M-3								
JEHS-0600-B3-M-3								
JEHS-0680-B3-M-3								
JEHS-0800-B4-M-3	1-1/4"-12UNF (110-135 Nm)	1-1/4"-12UNF (110-135 Nm)	M38*1.5mm (42-47Nm)	M25*1.0mm (42-47Nm)	N/A			7/16" - 20UNF (14-16 Nm)
JEHS-1000-B4-M-3								
JEHS-1300-B4-M-3	1-3/4"-12UNF (135-160 Nm)							
JEHS-1500-B6-M-3								
JEHR-0115-B1-L-1	Not Applicable (Braze Connection)		M18*1.0mm (25-30 Nm)	M16*1.0mm (20-25 Nm)	N/A	M14*1.5mm (25-30Nm)	Braze Connection Plug 3/8"NPT	
JEHR-0135-B1-L-1								
JEHR-0180-B2-L-1								
JEHR-0180-B2-L-3								
JEHR-0210-B2-L-1								
JEHR-0210-B2-L-3								
JEHS-0300-B2-L-3	1-1/4"-12UNF (110-135 Nm)		M25*1.0mm (42-47Nm)	M18*1.0mm (25-30 Nm)	N/A	N/A		
JEHS-0400-B3-L-3								
JEHS-0500-B3-L-3								
JEHS-0600-B3-L-3								
JEHS-0750-B4-L-3								
JEHS-0951-B4-L-3 EVI								
JEHS-1150-B4-L-3 EVI								
JEHS-1400-B4-L-3 EVI			1-3/4"-12UNF (135-160 Nm)					
Graphic Presentation					N/A			

F-Gas Requirement

The models of equipment covered in this Technical Manual rely on fluorinated greenhouse gases for their functioning.

All unit models come from the factory pressurized with OFN (Oxygen Free Nitrogen) only.

In F-Gas Regulation EU 517/2014, the requirement for leak testing on the system is based on the charge size in tonnes of CO₂ equivalent. Which means systems with higher GWP refrigerants will need to be leak tested more frequently than those with the same charge weight of a lower GWP refrigerant.

The GWP (Global Warming Potential) values of refrigerants which are specified for use along with the three new thresholds for leak testing requirements based on TCO₂Eq (Tonnes CO₂ Equivalent) are as follows:

Table 14: Tonnes CO₂ Equivalent

Refrigerant	GWP	Refrigerant Charge - kg		
		5T CO ₂ Eq	50T CO ₂ Eq	500T CO ₂ Eq
R134a	1430	3.5	35	350
R407A	2107	2.4	23.7	237
R407F	1825	2.7	27.4	274
R448A	1387	3.6	36.0	360
R449A	1397	3.6	35.8	358
R452A	2140	2.3	23.4	234

Starting 1st January 2017, the requirement for leak detection and maintaining system logs changes from 3kg HFC to 5 tonnes CO₂ equivalent.

Table 15: Leak Inspection Frequency

System Charge (Tonnes CO ₂ Equivalent)	Leak Inspection Frequency
e.g. 3.6 to 36 kg R448A	<ul style="list-style-type: none"> At least once every year.
5 to < 50	<ul style="list-style-type: none"> At least once every 2 years if a fixed leak detection system is fitted.
e.g. 36 to 360 kg R448A	<ul style="list-style-type: none"> At least once every 6 months.
50 to < 500	<ul style="list-style-type: none"> At least once every year if a fixed leak detection system is fitted.

- To calculate TCO₂ Eq value = $\frac{\text{Refrigerant Charge (kgs)} \times \text{Refrigerant GWP}}{1000}$

A refrigerant charge label is supplied with each unit (inside the electrical box). The total refrigerant charge for the system and the TCO₂ Eq value must be entered on the label with indelible ink and must be adhered in the proximity of the product charging port. The label supplied will represent the refrigerants approved for use with that unit. An example of the unit label is as follows:

Contains fluorinated greenhouse gases			
Ref.	GWP	Charge (kg)	TCO ₂ Eq.
R407A	2107		
R407F	1825		
R448A	1387		
R449A	1397		
R452A	2140		
R134a	1430		

Table 16: Trouble Shooting

FAULT	POSSIBLE CAUSE	CHECK	SOLUTION
COMPRESSOR			
Compressor will not start	Power supply	Phase(s) and neutral present?	Check/rectify
		Voltage within tolerance?	Check/rectify
		Is isolator switched on?	If not - switch on
	Compressor contactor not pulled in (where fitted)	Is there correct voltage to contactor coil?	If yes - coil faulty. Replace contactor/coil
		Has a safety switch tripped out?	If no - check for break in control circuit or blown control fuse. Check cause and reset
	Compressor contactor pulled in but compressor not running	Is voltage being switched across contactor?	If yes - check voltage at compressor terminals and compressor wiring If no - Replace the faulty contactor
	Safety switch tripped (LP, HP, Overload)	Low and High pressure conditions and current draw on overload. Check settings of safety switches are correct.	Reset and rectify any abnormal conditions or adjust switch settings if not set correctly

FAULT	POSSIBLE CAUSE	CHECK	SOLUTION
	Compressor internal overload tripped	Is the correct voltage at compressor terminals?	Compressor has overheated - allow time for reset (up to 3 hours) and rectify cause
	Control fuse blown in panel		Replace fuse and test - rectify fault
	Starting kit faulty (single phase units only)	Check relay operation and contacts and inspect start/run capacitors	Replace as necessary
	Motor windings faulty	Check resistances of windings against manufacturer values	Windings that show open circuit could be due to internal overload trip. Wait for reset and recheck. If continually open circuit - motor faulty. Replace compressor.
	Compressor seized	Does compressor attempt to start but does not run correctly (makes humming sound)? Are amps equivalent to LRC rating?	If all electrical checks on components as above are OK - Change compressor
Compressor runs but no effect on suction/discharge pressures	Mechanical failure	Are compressor motor amps lower than expected? If so - potentially valve reeds damaged or other internal wear/damage	Try pump test on compressor. If test fails - replace compressor.
	(For three-phase scroll compressors only)	The compressor may be running backwards - the compressor will also be noisier than normal	Swap any two of the incoming phases to the isolator switch and recheck.
Compressor starts and stops too quickly	Operating on safety switches	Check LP & HP settings - is the LP differential too small or the HP setting too low?	Check and adjust switch settings. Check all valves are in open position
	Refrigerant levels	Is there too little refrigerant in the system causing rapid LP tripping or too much refrigerant in the system causing HP tripping?	Check refrigerant level and adjust accordingly
	Faulty contactor (if fitted)	Are the contacts chattering on the contactor?	Contacts may be dirty or worn. Check and replace contactor as necessary
	Loose / broken wiring connection		Make sure all electrical connections are sound
Compressor is noisy	Vibration	Rubber feet mountings worn or bolts are loose/missing	Replace mountings and tighten/replace bolts as necessary
	Lack of oil	Check oil sight glass to see if level below recommended level	Top up with oil as necessary
	Too much oil	Check oil sight glass to see if level above recommended level	Remove oil overcharge
	Liquid refrigerant	Does compressor 'knock' when starting up or running? Liquid refrigerant may be present in oil and compression chambers	Identify cause of liquid return to compressor and rectify
	Overloaded	Are suction and discharge pressures too high? There may be too much load on the compressor.	Identify cause of increased load and rectify
	High discharge pressure	Blocked condenser / faulty condenser fan	Check and rectify
		Refrigerant overcharge	Check and rectify
		Non-condensibles in system	Reclaim refrigerant, evacuate & recharge
Internal wear / damage	Noise is always present even if all operating conditions are OK?	Replace compressor	
Compressor body too hot	System load too high	Are suction and discharge pressures high?	Reduce load at evaporator
	High discharge pressure	Blocked condenser / faulty condenser fan	Check and rectify
	Lack of compressor cooling	Suction superheat too high	Check refrigerant charge correct
			Check TEV superheat setting correct
Is suction line correctly insulated?			

FAULT	POSSIBLE CAUSE	CHECK	SOLUTION
	Compressor starting too frequently	Are controls set correctly - is the differential on thermostat or LP switch too small?	Check and adjust
		Is the liquid line solenoid valve allowing refrigerant to pass when closed?	Check valve and clean seat or replace as necessary if damaged
	Discharge gas bleeding into suction side	Does suction pressure rise abnormally when compressor stops or compressor fails to pump down correctly?	Compressor valve reeds may be damaged - replace compressor
CONDENSER FAN			
Condenser fan will not run	Power supply	See compressor will not start section	See compressor will not start section
	Compressor contactor not pulled in	See compressor will not start section	See compressor will not start section
	Compressor contactor pulled in	Is voltage being switched across contactor?	If yes - check voltage to FSC and to fan motor. If correct voltage present at motor - fan faulty. Replace fan
			If no. Replace faulty contactor
	Being controlled by FSC (if fitted)	Is system operating pressure below FSC setting?	If yes - all OK (check fan operates when pressure rises)
	Fan capacitor fault	Check visual condition of capacitor and check capacitance reading with capacitor meter.	Replace capacitor if required
	Motor fault	If FSC fitted - bypass FSC to test motor. If motor still does not run - motor is faulty	Replace motor
Condenser fan runs but only slowly	Is fan being controlled by FSC?	Is head pressure under control (~14/15 bar on R448A/449A) and fan speed increases as head pressure rises?	All OK
		Is head pressure above 16 bar (R448/449A)?	Check setting of FSC. Adjust if necessary.
	FSC faulty	If fan runs slowly even after adjusting FSC with head pressure rising - FSC may be faulty	Change FSC
SYSTEM			
Insufficient cooling	Lack of refrigerant	Is sight glass flashing continuously?	Leak test system and top up with refrigerant
	Condenser coil dirty	Visual check of coil condition	Clean condenser coil
	Lack of ventilation to unit	Any obstructions around unit?	Clear same to ensure good ventilation
	Compressor not pumping efficiently	Carry out pump test on compressor	Replace compressor if fails pump test
	System settings	Controls (inc thermostat) set correctly?	Adjust as necessary
		T.E.V. Superheat	Adjust as necessary
	Service valves do not open correctly	Are valves fully open?	Adjust as necessary
	Restriction in piping/component	Is the filter drier blocked? Sweating/frosting on outlet of drier indicates a blockage	Replace filter drier
		Damage to piping	Replace piping as required
Head pressure too high	Condenser coil dirty	Visual check of coil condition	Clean condenser coil
	System overcharged with refrigerant	Is head pressure high but liquid line cool to touch?	Reclaim refrigerant/recharge correctly
	Condenser fan not running	See above (fan will not run)	See above
	FSC (if fitted) not set correctly	Check setting against gauge pressure	Adjust as necessary
	Lack of ventilation to unit	Any obstructions around unit?	Clear same to ensure good ventilation
	System load too high (overstocked, door open on cold-room)		Reduce loading

Figure 33: Declaration of conformity



Declaration of Conformity

According to SI 2016 No. 1105 SCHEDULE 11, SI 2010 No. 2617 SCHEDULE 1

We: J & E Hall International
of: Questor House, 191 Hawley Road, Dartford, Kent, DA1 1PU

Declare under sole responsibility that

The Product: Refrigeration Condensing Unit

Model Designations:

JEHS-0200-B2-M-1	JEHS-0600-B3-M-3	JEHR-0067-B1-M-1
JEHS-0200-B2-M-3	JEHS-0680-B3-M-3	JEHR-0100-B1-M-1
JEHS-0250-B2-M-1	JEHS-0800-B4-M-3	JEHR-0113-B1-M-1
JEHS-0250-B2-M-3	JEHS-1000-B4-M-3	JEHR-0140-B2-M-1
JEHS-0300-B2-M-1	JEHS-1300-B4-M-3	JEHR-0140-B2-M-3
JEHS-0300-B2-M-3	JEHS-1500-B6-M-3	JEHR-0170-B2-M-1
JEHS-0350-B2-M-1	JEHS-0400-B3-L-3	JEHR-0170-B2-M-3
JEHS-0350-B2-M-3	JEHS-0500-B3-L-3	JEHR-0115-B1-L-1
JEHS-0300-B2-L-3	JEHS-0600-B3-L-3	JEHR-0135-B1-L-1
JEHS-0350-B3-M-1	JEHS-0750-B4-L-3	JEHR-0180-B1-L-1
JEHS-0350-B3-M-3	JEHS-0951-B4-L-3 EVI	JEHR-0180-B2-L-3
JEHS-0400-B3-M-1	JEHS-1150-B4-L-3 EVI	JEHR-0210-B2-L-1
JEHS-0400-B3-M-3	JEHS-1400-B4-L-3 EVI	JEHR-0210-B2-L-3
JEHS-0500-B3-M-3	JEHR-0050-B1-M-1	

Description: Fusion / Fusion Scroll Commercial Condensing Units for Medium and Low Temperature Applications

SI 2016 No. 1105 Conformity Assessment Procedure Followed: Module A – for JEHS-0200-B2-M-1 JEHS-0200-B2-M-3 JEHS-0250-B2-M-1 JEHS-0250-B2-M-3 JEHS-0300-B2-M-1 JEHS-0300-B2-M-3 JEHS-0350-B2-M-1 JEHS-0350-B2-M-3 JEHS-0300-B2-L-3 JEHR-0050-B1-M-1 JEHR-0067-B1-M-1 JEHR-0100-B1-M-1 JEHR-0113-B1-M-1 JEHR-0140-B2-M-1 JEHR-0140-B2-M3 JEHR-0170-B2-M-1 JEHR-0170-B2-M-3 JEHR-0115-B1-L-1 JEHR-0135-B1-L1 JEHR-0180-B1-L-1 JEHR-0180-B2-L-3 JEHR-0210-B2-L-1 JEHR-0210-B2-L-3

Module A2 – for JEHS-0350-B3-M-1 JEHS-0350-B3-M-3 JEHS-0400-B3-M-1 JEHS-0400-B3-M-3 JEHS-0500-B3-M-3 JEHS-0600-B3-M-3 JEHS-0680-B3-M-3 JEHS-0800-B4-M-3 JEHS-1000-B4-M-3 JEHS-1300-B4-M-3 JEHS-1500-B6-M-3 JEHS-0400-B3-L-3 JEHS-0500-B3-L-3 JEHS-0600-B3-L-3 JEHS-0750-B4-L-3 JEHS-0951-B4-L-3 EVI JEHS-1150-B4-L-3 EVI JEHS-1400-B4-L-3 EVI

Description of the pressure equipment constituting the assembly:

Part description	Conformity assessment followed
Pressure switch	Module D1 / B + D
Compressor	Module A2 / D1
Liquid receiver	Module A / H1 / E
Oil separator	Module A / H1
Filter drier	SEP
Condenser	SEP
Sight glass & Valves	SEP
Flexible hose, System piping & Pressure accessories	SEP

The object of the declaration described above is in conformity with the following statutory requirements and implementing measures:

SI 2016 No. 1105	The Pressure Equipment (Safety) Regulations
Commission Regulation (EU) 2015/1095	Commission Regulation (EU) 2015/1095 of 5 May 2015 implementing Directive 2009/125/EC of the European Parliament and of the Council with regard to ecodesign requirements for professional refrigerated storage cabinets, blast cabinets, condensing units and process chillers

It has been designed and manufactured to the following designated standards and technical specifications:

- BS EN 60335-1 Household and similar electrical appliances. Safety. General requirements
- BS EN 60335-2-89 Household and similar electrical appliances. Safety. Particular requirements for commercial refrigerating appliances with an incorporated or remote refrigerant unit or compressor
- BS EN 13215 Condensing units for refrigeration. Rating conditions, tolerances and presentation of manufacturer's performance data
- DG-0001 Pressure Equipment

SI 2016 No. 1105 conformity assessment was carried out by Hartford Steam Boiler UK (Approved Body Number: 2561), 9th Floor, Chancery Place, 50 Brown Street, Manchester M2 2JT, United Kingdom with Marking Permission HSB UK-22-09-004 issued.

Signed:



Name:

Andrew Bowden

Position:

Managing Director

Location:

J & E Hall Limited, Questor House, 191 Hawley Road, Dartford, Kent, DA1 1PU

Date:

23/11/2022



Declaration of Incorporation

According to SI 2008 No. 1597 Annex II

We: J & E Hall International
of: Questor House, 191 Hawley Road, Dartford, Kent, DA1 1PU

Declare that for below

Product Refrigeration Condensing Unit

Model Designations:

JEHS-0200-B2-M-1	JEHS-0600-B3-M-3	JEHR-0067-B1-M-1
JEHS-0200-B2-M-3	JEHS-0680-B3-M-3	JEHR-0100-B1-M-1
JEHS-0250-B2-M-1	JEHS-0800-B4-M-3	JEHR-0113-B1-M-1
JEHS-0250-B2-M-3	JEHS-1000-B4-M-3	JEHR-0140-B2-M-1
JEHS-0300-B2-M-1	JEHS-1300-B4-M-3	JEHR-0140-B2-M-3
JEHS-0300-B2-M-3	JEHS-1500-B6-M-3	JEHR-0170-B2-M-1
JEHS-0350-B2-M-1	JEHS-0400-B3-L-3	JEHR-0170-B2-M-3
JEHS-0350-B2-M-3	JEHS-0500-B3-L-3	JEHR-0115-B1-L-1
JEHS-0300-B2-L-3	JEHS-0600-B3-L-3	JEHR-0135-B1-L-1
JEHS-0350-B3-M-1	JEHS-0750-B4-L-3	JEHR-0180-B1-L-1
JEHS-0350-B3-M-3	JEHS-0951-B4-L-3 EVI	JEHR-0180-B2-L-3
JEHS-0400-B3-M-1	JEHS-1150-B4-L-3 EVI	JEHR-0210-B2-L-1
JEHS-0400-B3-M-3	JEHS-1400-B4-L-3 EVI	JEHR-0210-B2-L-3
JEHS-0500-B3-M-3	JEHR-0050-B1-M-1	

Description: Fusion / Fusion Scroll Commercial Condensing Units for Medium and Low Temperature Applications

The following essential health and safety requirements of The Supply of Machinery (Safety) Regulations 2008 (SI 2008 No. 1597) are applied and fulfilled:

1.1.1 – 1.1.2 – 1.1.3 – 1.1.5 – 1.2.1 - 1.2.6 - 1.3.2 – 1.3.3 – 1.3.4 – 1.3.7 – 1.3.8.2 – 1.4.1 – 1.4.2.1 – 1.5.1 – 1.5.2 – 1.5.13 – 1.7.1.1 – 1.7.2 – 1.7.3 – 1.7.4

The relevant technical documentation has been compiled in accordance with Annex VII (PART 7 of SCHEDULE 2) part B of SI 2008 No. 1597.

The partly completed machinery is also in conformity with below enactments:

SI 2016 No. 1105	The Pressure Equipment (Safety) Regulations
Commission Regulation (EU) 2015/1095	Commission Regulation (EU) 2015/1095 of 5 May 2015 implementing Directive 2009/125/EC of the European Parliament and of the Council with regard to eco-design requirements for professional refrigerated storage cabinets, blast cabinets, condensing units and process chillers

The relevant information can be transmitted in electronic form in response to a reasoned request by the national authorities.

The partly completed machinery must not be put into service until the final machinery into which it is to be incorporated has been declared in conformity with the provisions of these Regulations, where appropriate.

The legal representative authorised to compile the relevant technical documentation is J & E Hall Limited, Questor House, 191 Hawley Road, Dartford, Kent, United Kingdom, DA1 1PU.

Signed:

Name: Andrew Bowden

Position: Managing Director

Location: J & E Hall Limited, Questor House, 191 Hawley Road, Dartford, Kent, DA1 1PU

Date: 23/11/2022

Figure 35: EU Declaration of conformity

EU Declaration of Conformity																																												
According to DIRECTIVE 2014/68/EU ANNEX IV, DIRECTIVE 2009/125/EC ANNEX VI																																												
We:	J & E Hall International																																											
of:	Questor House, 191 Hawley Road, Dartford, Kent, DA1 1PU																																											
Declare under sole responsibility that																																												
The Product:	Refrigeration Condensing Unit																																											
Model Designations:	<table border="0"> <tr><td>JEHS-0200-B2-M-1</td><td>JEHS-0600-B3-M-3</td><td>JEHR-0067-B1-M-1</td></tr> <tr><td>JEHS-0200-B2-M-3</td><td>JEHS-0680-B3-M-3</td><td>JEHR-0100-B1-M-1</td></tr> <tr><td>JEHS-0250-B2-M-1</td><td>JEHS-0800-B4-M-3</td><td>JEHR-0113-B1-M-1</td></tr> <tr><td>JEHS-0250-B2-M-3</td><td>JEHS-1000-B4-M-3</td><td>JEHR-0140-B2-M-1</td></tr> <tr><td>JEHS-0300-B2-M-1</td><td>JEHS-1300-B4-M-3</td><td>JEHR-0140-B2-M-3</td></tr> <tr><td>JEHS-0300-B2-M-3</td><td>JEHS-1500-B6-M-3</td><td>JEHR-0170-B2-M-1</td></tr> <tr><td>JEHS-0350-B2-M-1</td><td>JEHS-0400-B3-L-3</td><td>JEHR-0170-B2-M-3</td></tr> <tr><td>JEHS-0350-B2-M-3</td><td>JEHS-0500-B3-L-3</td><td>JEHR-0115-B1-L-1</td></tr> <tr><td>JEHS-0300-B2-L-3</td><td>JEHS-0600-B3-L-3</td><td>JEHR-0135-B1-L-1</td></tr> <tr><td>JEHS-0350-B3-M-1</td><td>JEHS-0750-B4-L-3</td><td>JEHR-0180-B1-L-1</td></tr> <tr><td>JEHS-0350-B3-M-3</td><td>JEHS-0951-B4-L-3 EVI</td><td>JEHR-0180-B2-L-3</td></tr> <tr><td>JEHS-0400-B3-M-1</td><td>JEHS-1150-B4-L-3 EVI</td><td>JEHR-0210-B2-L-1</td></tr> <tr><td>JEHS-0400-B3-M-3</td><td>JEHS-1400-B4-L-3 EVI</td><td>JEHR-0210-B2-L-3</td></tr> <tr><td>JEHS-0500-B3-M-3</td><td>JEHR-0050-B1-M-1</td><td></td></tr> </table>		JEHS-0200-B2-M-1	JEHS-0600-B3-M-3	JEHR-0067-B1-M-1	JEHS-0200-B2-M-3	JEHS-0680-B3-M-3	JEHR-0100-B1-M-1	JEHS-0250-B2-M-1	JEHS-0800-B4-M-3	JEHR-0113-B1-M-1	JEHS-0250-B2-M-3	JEHS-1000-B4-M-3	JEHR-0140-B2-M-1	JEHS-0300-B2-M-1	JEHS-1300-B4-M-3	JEHR-0140-B2-M-3	JEHS-0300-B2-M-3	JEHS-1500-B6-M-3	JEHR-0170-B2-M-1	JEHS-0350-B2-M-1	JEHS-0400-B3-L-3	JEHR-0170-B2-M-3	JEHS-0350-B2-M-3	JEHS-0500-B3-L-3	JEHR-0115-B1-L-1	JEHS-0300-B2-L-3	JEHS-0600-B3-L-3	JEHR-0135-B1-L-1	JEHS-0350-B3-M-1	JEHS-0750-B4-L-3	JEHR-0180-B1-L-1	JEHS-0350-B3-M-3	JEHS-0951-B4-L-3 EVI	JEHR-0180-B2-L-3	JEHS-0400-B3-M-1	JEHS-1150-B4-L-3 EVI	JEHR-0210-B2-L-1	JEHS-0400-B3-M-3	JEHS-1400-B4-L-3 EVI	JEHR-0210-B2-L-3	JEHS-0500-B3-M-3	JEHR-0050-B1-M-1	
JEHS-0200-B2-M-1	JEHS-0600-B3-M-3	JEHR-0067-B1-M-1																																										
JEHS-0200-B2-M-3	JEHS-0680-B3-M-3	JEHR-0100-B1-M-1																																										
JEHS-0250-B2-M-1	JEHS-0800-B4-M-3	JEHR-0113-B1-M-1																																										
JEHS-0250-B2-M-3	JEHS-1000-B4-M-3	JEHR-0140-B2-M-1																																										
JEHS-0300-B2-M-1	JEHS-1300-B4-M-3	JEHR-0140-B2-M-3																																										
JEHS-0300-B2-M-3	JEHS-1500-B6-M-3	JEHR-0170-B2-M-1																																										
JEHS-0350-B2-M-1	JEHS-0400-B3-L-3	JEHR-0170-B2-M-3																																										
JEHS-0350-B2-M-3	JEHS-0500-B3-L-3	JEHR-0115-B1-L-1																																										
JEHS-0300-B2-L-3	JEHS-0600-B3-L-3	JEHR-0135-B1-L-1																																										
JEHS-0350-B3-M-1	JEHS-0750-B4-L-3	JEHR-0180-B1-L-1																																										
JEHS-0350-B3-M-3	JEHS-0951-B4-L-3 EVI	JEHR-0180-B2-L-3																																										
JEHS-0400-B3-M-1	JEHS-1150-B4-L-3 EVI	JEHR-0210-B2-L-1																																										
JEHS-0400-B3-M-3	JEHS-1400-B4-L-3 EVI	JEHR-0210-B2-L-3																																										
JEHS-0500-B3-M-3	JEHR-0050-B1-M-1																																											
Description:	Fusion / Fusion Scroll Commercial Condensing Units for Medium and Low Temperature Applications																																											
DIRECTIVE 2014/68/EU Conformity Assessment Procedure Followed:	<p>Module A – for JEHS-0200-B2-M-1 JEHS-0200-B2-M-3 JEHS-0250-B2-M-1 JEHS-0250-B2-M-3 JEHS-0300-B2-M-1 JEHS-0300-B2-M-3 JEHS-0350-B2-M-1 JEHS-0350-B2-M-3 JEHS-0300-B2-L-3 JEHR-0050-B1-M-1 JEHR-0067-B1-M-1 JEHR-0100-B1-M-1 JEHR-0113-B1-M-1 JEHR-0140-B2-M-1 JEHR-0140-B2-M-3 JEHR-0170-B2-M-1 JEHR-0170-B2-M-3 JEHR-0115-B1-L-1 JEHR-0135-B1-L-1 JEHR-0180-B1-L-1 JEHR-0180-B2-L-3 JEHR-0210-B2-L-1 JEHR-0210-B2-L-3</p> <p>Module A2 – for JEHS-0350-B3-M-1 JEHS-0350-B3-M-3 JEHS-0400-B3-M-1 JEHS-0400-B3-M-3 JEHS-0500-B3-M-3 JEHS-0600-B3-M-3 JEHS-0680-B3-M-3 JEHS-0800-B4-M-3 JEHS-1000-B4-M-3 JEHS-1300-B4-M-3 JEHS-1500-B6-M-3 JEHS-0400-B3-L-3 JEHS-0500-B3-L-3 JEHS-0600-B3-L-3 JEHS-0750-B4-L-3 JEHS-0951-B4-L-3 EVI JEHS-1150-B4-L-3 EVI JEHS-1400-B4-L-3 EVI</p>																																											
Description of the pressure equipment constituting the assembly:																																												
Part description	Conformity assessment followed																																											
Pressure switch	Module D1 / B + D																																											
Compressor	Module A2 / D1																																											
Liquid receiver	Module A / H1 / E																																											
Oil separator	Module A / H1																																											
Filter drier	SEP																																											
Condenser	SEP																																											
Sight glass & Valves	SEP																																											
Flexible hose, System piping & Pressure accessories	SEP																																											
The object of the declaration described above is in conformity with the following Union harmonisation legislation:																																												
DIRECTIVE 2014/68/EU	On the harmonisation of the laws of the Member States relating to the making available on the market of pressure equipment																																											
Commission Regulation (EU) 2015/1095	Commission Regulation (EU) 2015/1095 of 5 May 2015 implementing Directive 2009/125/EC of the European Parliament and of the Council with regard to ecodesign requirements for professional refrigerated storage cabinets, blast cabinets, condensing units and process chillers																																											
Form: JEH-C6-017e-01	Questor House, 191 Hawley Road, Dartford, Kent, DA1 1PU	Page 1 of 2																																										

Continued.

It has been designed and manufactured to the following harmonised standards and technical specifications:

- BS EN 60335-1 Household and similar electrical appliances. Safety. General requirements
- BS EN 60335-2-89 Household and similar electrical appliances. Safety. Particular requirements for commercial refrigerating appliances with an incorporated or remote refrigerant unit or compressor
- BS EN 13215 Condensing units for refrigeration. Rating conditions, tolerances and presentation of manufacturer's performance data
- DG-0001 Pressure Equipment

DIRECTIVE 2014/68/EU conformity assessment was carried out by Hartford Steam Boiler UK (Notified Body number: 2833) 28 Windsor Place, Lower Pembroke Street, Dublin 2, Ireland with Marking Permission HSB IE 22-09-003 issued.

Signed:



Name:

Andrew Bowden

Position:

Managing Director



Location:

J & E Hall Limited, Questor House, 191 Hawley Road, Dartford, Kent, DA1 1PU

Date:

23/11/2022

Figure 36: EU Declaration of incorporation

Declaration of Incorporation		
According to DIRECTIVE 2006/42/EC Annex II		
We:	J & E Hall International	
of:	Questor House, 191 Hawley Road, Dartford, Kent, DA1 1PU	
Declare that for below		
Product	Refrigeration Condensing Unit	
Model Designations:	JEHS-0200-B2-M-1 JEHS-0600-B3-M-3 JEHR-0067-B1-M-1 JEHS-0200-B2-M-3 JEHS-0680-B3-M-3 JEHR-0100-B1-M-1 JEHS-0250-B2-M-1 JEHS-0800-B4-M-3 JEHR-0113-B1-M-1 JEHS-0250-B2-M-3 JEHS-1000-B4-M-3 JEHR-0140-B2-M-1 JEHS-0300-B2-M-1 JEHS-1300-B4-M-3 JEHR-0140-B2-M-3 JEHS-0300-B2-M-3 JEHS-1500-B6-M-3 JEHR-0170-B2-M-1 JEHS-0350-B2-M-1 JEHS-0400-B3-L-3 JEHR-0170-B2-M-3 JEHS-0350-B2-M-3 JEHS-0500-B3-L-3 JEHR-0115-B1-L-1 JEHS-0300-B2-L-3 JEHS-0600-B3-L-3 JEHR-0135-B1-L-1 JEHS-0350-B3-M-1 JEHS-0750-B4-L-3 JEHR-0180-B1-L-1 JEHS-0350-B3-M-3 JEHS-0951-B4-L-3 EVI JEHR-0180-B2-L-3 JEHS-0400-B3-M-1 JEHS-1150-B4-L-3 EVI JEHR-0210-B2-L-1 JEHS-0400-B3-M-3 JEHS-1400-B4-L-3 EVI JEHR-0210-B2-L-3 JEHS-0500-B3-M-3 JEHR-0050-B1-M-1	
Description:	Fusion / Fusion Scroll Commercial Condensing Units for Medium and Low Temperature Applications	
The following essential health and safety requirements of the Machinery Directive (DIRECTIVE 2006/42/EC) are applied and fulfilled:		
1.1.1 – 1.1.2 – 1.1.3 – 1.1.5 – 1.2.1 - 1.2.6 - 1.3.2 – 1.3.3 – 1.3.4 – 1.3.7 – 1.3.8.2 – 1.4.1 – 1.4.2.1 – 1.5.1 – 1.5.2 – 1.5.13 – 1.7.1.1 – 1.7.2 – 1.7.3 – 1.7.4		
The relevant technical documentation has been compiled in accordance with part B of Annex VII of DIRECTIVE 2006/42/EC.		
The partly completed machinery is also in conformity with below Directives and Regulations:		
DIRECTIVE 2014/68/EU	On the harmonisation of the laws of the Member States relating to the making available on the market of pressure equipment	
Commission Regulation (EU) 2015/1095	Commission Regulation (EU) 2015/1095 of 5 May 2015 implementing Directive 2009/125/EC of the European Parliament and of the Council with regard to eco-design requirements for professional refrigerated storage cabinets, blast cabinets, condensing units and process chillers	
The relevant information can be transmitted in electronic form in response to a reasoned request by the national authorities.		
The partly completed machinery must not be put into service until the final machinery into which it is to be incorporated has been declared in conformity with the provisions of DIRECTIVE 2006/42/EC, where appropriate.		
The legal representative authorised to compile the relevant technical documentation is TEWIS SMART SYSTEMS, S.L.U, Auguste y Louis Lumière, 26 Parque tecnológico, Paterna, Valencia, Spain.		
Signed:		
Name:	Andrew Bowden	
Position:	Managing Director	
Location:	J & E Hall Limited, Questor House, 191 Hawley Road, Dartford, Kent, DA1 1PU	
Date:	23/11/2022	
<hr/>		
Form: JEH-C6-016e-01	Questor House, 191 Hawley Road, Dartford, Kent, DA1 1PU	Page 1 of 1

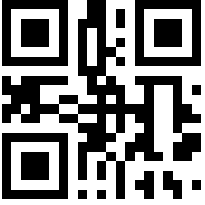

RJ0110030007408

J & E Hall Limited
Hansard Gate
West Meadows
Derby, DE21 6JN
England

Tel: + 44 (0) 1332 253400
Fax: + 44 (0) 1332 371061
Email: helpline@jehall.co.uk
www.jehall.com

Issue: 01.06.2023

